

Technical Description

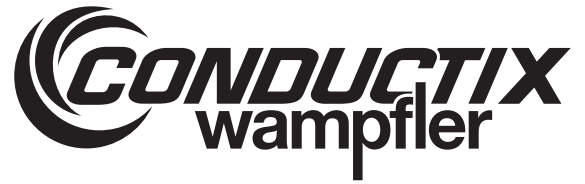

ISP 3.0 Inductive Stationary Pad IMP 3.0 Inductive Mobile Pad

Item number	WNR	
3267991	CWA-60693001	ISP 3.0
3267993	CWA-60693000	IMP 3.0

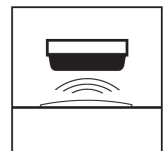
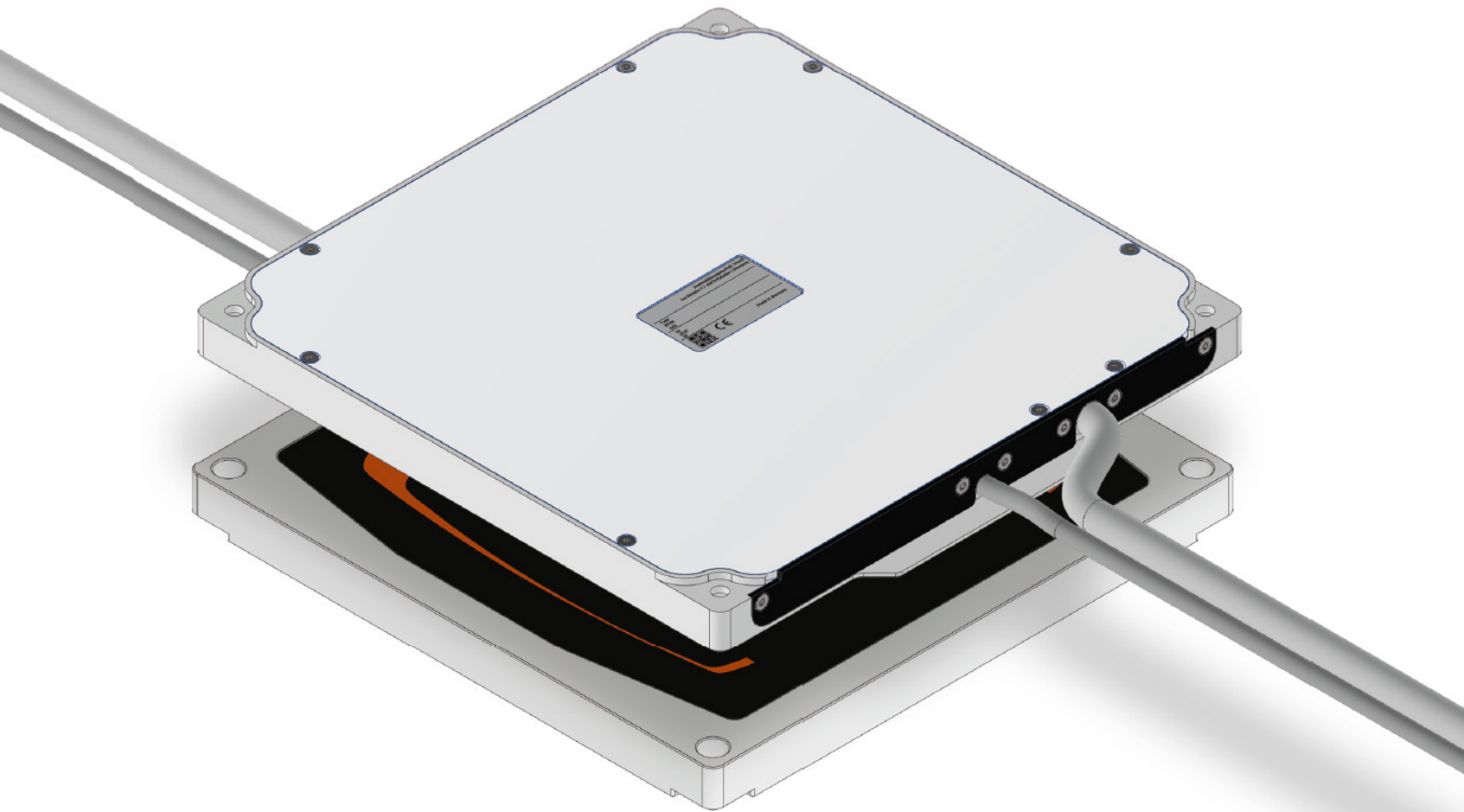

Conductix-Wampfler Automation GmbH
Handelshof 16 A
14478 Potsdam
Germany
Telephone: +49 (0)331 887433-0
Fax: +49 (0)331 887433-19
Email: info.potsdam@conductix.com
Internet: www.conductix.com
Translation of the original
TNB_0073, 5, en_GB

Table of contents

1	Information on the description.....	7
1.1	Revision history.....	7
1.2	How to use and store the description.....	7
1.3	Applicable documents.....	7
1.4	Copyright protection.....	8
1.5	Illustrations.....	8
1.6	Brands.....	8
2	Warranty and liability.....	9
2.1	Warranty.....	9
2.2	Limitation of liability.....	9
3	Safety instructions.....	10
3.1	Warning concept.....	10
3.1.1	Arrangement of warnings.....	10
3.1.2	Structure of warnings.....	10
3.1.3	Signal words.....	11
3.1.4	Hazard symbols.....	11
3.1.5	Suggestions and recommendations.....	11
3.2	Intended use.....	12
3.3	Foreseeable incorrect use.....	12
3.4	Modifications and alterations.....	13
3.5	Responsibility of the operator.....	14
3.6	Personnel and qualifications.....	14
3.7	Special hazards.....	17
3.8	Safety devices.....	18
4	Wireless Charger WC 3.0 - system overview.....	19
4.1	Components.....	19
4.2	How it works.....	20
4.3	Control circuit.....	21
4.4	Controlling the charging process.....	21
4.4.1	Charging process - Continuous.....	23
4.4.2	Charging process - controlled by BMS controller.....	24
4.4.3	Charging process - controlled by BMS and PLC.....	25
4.4.4	Charging process - controlled by PLC.....	26
4.4.5	Charging process - controlled by AGV controller.....	27
4.5	Enable commands for charging process.....	28
4.6	Inductive communication.....	29

5	Product description	30
5.1	Structure.....	30
5.2	Function.....	30
5.3	Type label.....	31
5.4	Scope of delivery.....	31
5.4.1	Device.....	31
5.4.2	Product sets.....	32
6	Transport and storage	33
6.1	Transport.....	33
6.2	Transport inspection.....	33
6.3	Storage.....	34
7	Mechanical installation	35
7.1	Installation location and position.....	37
7.2	Open spaces and cooling.....	38
7.3	Metal-free area.....	39
7.4	Installation.....	40
7.5	Pad alignment.....	42
7.5.1	Vertical alignment.....	42
7.5.2	Horizontal alignment.....	43
7.5.3	Radial alignment.....	44
7.5.4	Working range.....	45
8	Electrical installation	46
8.1	Cable routing.....	48
8.1.1	Laying cables in the ground.....	50
8.1.2	Laying cables in a cable duct.....	50
8.1.3	Shortening cables.....	53
8.2	Electrical connection of the pads.....	54
8.3	Floor conductivity.....	56
9	Commissioning	57
10	Operation	58
10.1	Electromagnetic field.....	58
10.2	Charging process.....	61
10.2.1	Automatic adjustment of the primary current.....	61
10.2.2	Temperature generation during the charging process.....	61
10.2.3	Power reduction with temperature increase.....	62
10.2.4	Power reduction in case of pad displacement.....	63
11	Faults	64

12	Maintenance and cleaning	65
12.1	Maintenance.....	66
12.2	Cleaning.....	66
13	Information on disposal and environmental regulations	67
14	Technical Data	68
14.1	Dimensions.....	68
14.2	Weight.....	68
14.3	Material.....	68
14.4	Cooling.....	69
14.5	Load-bearing capacity.....	69
14.6	Environmental conditions.....	69
14.7	ISP input data.....	71
14.8	IMP output data.....	71
14.9	Cable lengths and specifications.....	71
14.10	Approvals and standards.....	72
15	Customer service and addresses	73
16	Index	75
	Appendix	77

1 Information on the description

1.1 Revision history

Subject to changes

We reserve the right to make changes to the information present in this document, which result from our constant effort to improve our products.

Version	Date	Comment/reason for change
1	04.2022	Basic version
2	05.2022	Assembly frame removed
3	05.2022	Approvals and standards updated
4	11.2022	Corrections to content
5	01.2023	First released version

1.2 How to use and store the description

To work safely with the product, it is necessary to observe the safety notes and action instructions. All persons working with the product must have understood the user information in this description and apply it conscientiously. The operator must fulfil his duty of care and ensure that all persons working with the product have read and understood the user information and are implementing it.



This description forms part of the product and must be accessible to all persons working with the product at all times.

1.3 Applicable documents

The documents contained in the project documentation also apply if the device / system is part of a project-specific system plan.

Their own documentation applies to connected devices and components.

Technical documentations

Hardware	Related description
IPS 3.0 Inductive Power Supply	 TNB_0083_IPS30
ISP 3.0 Inductive Stationary Pad	 TNB_0073_ISP30_IMP30
IMP 3.0 Inductive Mobile Pad	
MPU 3.0 Mobile Power Unit	 TNB_0085_MPU30

Software	Related description
Wireless Charger 3.0 Web Interface	 SWB_0021_Wireless-Charger-Web-Interface_User_Admin



The documents are included in the scope of delivery of the respective device or can be downloaded from our website www.conductix.com.

1.4 Copyright protection

The contents, texts, drawings, pictures and other illustrations of this description are protected by copyright and subject to intellectual property rights. Any misuse is punishable by law.

Reproduction in whole or in part of this description is only permitted within the limits of the legal provisions of the copyright law. Any modification or shortening of the text is prohibited without the explicit written consent of Conductix-Wampfler Automation GmbH.

1.5 Illustrations

The illustrations that accompany this description have been purposely selected. They are provided for basic understanding and may differ from the actual design. No claims shall be accepted for possible discrepancies.

1.6 Brands

The popular names, trade names, production descriptions, etc. used in this description may constitute trademarks even without special designations and as such may be subject to legal requirements.

2 Warranty and liability

2.1 Warranty

The warranty only covers production defects and faulty components.

The manufacturer assumes no responsibility for damages caused during transport or unpacking. In no case and under no circumstances will the manufacturer be liable for defects or damages caused by misuse, incorrect installation or inadequate environmental conditions or from dust or corrosive substances.

Consequential damages are excluded from the warranty.

Should you have further questions regarding the warranty, please contact the supplier.

2.2 Limitation of liability

All information and notes in this description have been compiled taking into account the applicable standards and regulations, the state of the art and our many years of knowledge and experience.

Conductix-Wampfler Automation GmbH assumes no liability for damage and malfunctions during operation due to:

- Failure to comply with the description
- Non-intended use
- Use by untrained personnel
- Unauthorised alteration or modification
- Use of the product, despite negative transport inspection

Furthermore, Conductix-Wampfler Automation GmbH's warranty obligation will cease to exist in case of a failure to comply with the description.

3 Safety instructions

This section contains information on all safety aspects for optimum protection of personnel and for safe operation without malfunctions.

To prevent dangers, these notes must be read and followed by personnel. Only then can safe operation be guaranteed.

Of course, all legally applicable general safety and accident prevention regulations must be complied with.

Conductix-Wampfler Automation GmbH assumes no liability for damage or accidents that were caused by non-observance of these safety notes.

3.1 Warning concept

This description contains notes that must be observed for your own personal safety and to avoid property damage. Notes regarding your personal safety are highlighted by a warning triangle; notes regarding property damage do not have a warning triangle.

When several hazard levels occur, the warning always refers to the highest level. If a warning of injury to persons is indicated with a warning triangle, the same warning might include an additional warning of property damage.

3.1.1 Arrangement of warnings

If warnings refer to an entire section, they are placed at the beginning of the section (e.g. chapter start).





If warnings refer to a specific action instruction, they are placed in front of the respective action instruction.

3.1.2 Structure of warnings

- **SIGNAL WORD**
- ↳ Type of danger and its source
- ↳ Possible consequences, if not observed
- ↳ Danger avoidance measures
- ↳ Preventive measures

3.1.3 Signal words



Warnings are indicated using signal words based on hazard levels.

Signal word	Meaning
 	This combination of symbol and signal word indicates a possible dangerous situation that can result in death or serious injury if it is not avoided.
 	This combination of symbol and signal word indicates a possible dangerous situation that can result in material damage if it is not avoided.

3.1.4 Hazard symbols

Warnings of the groups 'danger' and 'warning' are content-based. They are presented with clear danger symbols.

Warnings of the 'caution' group do not have a specific danger symbol.

Warning signs	Type of danger
	Warning – high-voltage.
	Warning – non-ionising electromagnetic radiation.
	Warning – danger zone.

3.1.5 Suggestions and recommendations



This symbol indicates important information to help you handle the product.

3.2 Intended use

The devices have been designed and constructed exclusively for the intended use described below.

The ISP 3.0 (Inductive Stationary Pad) and IMP 3.0 (Inductive Mobile Pad) charging pads

- are devices designed for use in commercial and industrial transport systems.
- are part of the '*Wireless Charger 3.0*' inductive charging system for charging batteries in AGVs.
- are used to transmit power to the AGVs at fixed positions without contact.
 - The ISP 3.0 is the transmitting coil installed in a stationary position in the inductive charging system.
 - The IMP 3.0 is the receiving coil of the inductive charging system installed on the AGV.

The intended use includes compliance with all of the information in this manual and the associated documents.

Any use beyond that intended or other types of use are regarded as misuse.

3.3 Foreseeable incorrect use

Any use that goes beyond this description is forbidden.



⚠ WARNING!

Hazard from non-intended use!

Any use of the device other than and/or beyond the intended use can cause hazardous situations.

- Only use the device as intended.
- It is paramount to comply with all the specifications and permitted conditions at the place of use.
- Do not use the device in potentially explosive atmospheres.
- Do not operate the device in environments with harmful oils, gases, vapours, dusts, radiation, etc.



NOTICE!

Components of the charging system

The components of the charging system are coordinated with each other and form a system unit. Operation with third-party equipment leads to damage and failure of the system!

- The system is not compatible with devices from other manufacturers.
- Operate the system only with the components intended for it.

3.4 Modifications and alterations

For the purpose of avoiding hazards and for ensuring optimum performance, any modifications, additions, or alterations to the device require Conductix-Wampfler Automation GmbH's express consent.



⚠ WARNING!

Injury hazard from structural modifications!

Unauthorised technical modifications can cause bodily harm or material damage.

- Replace faulty devices.
- A faulty device should only be replaced by an identical device.

3.5 Responsibility of the operator

Responsibility of the operator

The device is used in an industrial environment. The operator of the device is therefore subject to statutory obligations regarding work safety.

In addition to the work safety instructions in this description, the safety, accident prevention and environmental regulations applicable to the area where the device is used must be complied with.

The following applies in particular:

- The operators must familiarise themselves with the applicable work safety regulations and must also determine the dangers that are posed by the particular work conditions at the location of use by means of a risk assessment. This must be realised in the form of operating instructions for operation.
- This description must be kept within easy reach of the device and be accessible to those persons working with it at all times.
- The specifications of the description must be adhered to fully and unconditionally!
- The device may only be operated when in a perfect and operationally safe condition. It must be checked for detectable defects prior to each time it is put into service.
- The owner must ensure that the responsibilities for activities performed on the device are clearly defined. Only sufficiently qualified personnel who are familiar with the operating instructions and safety instructions may work with and on the device.

3.6 Personnel and qualifications

The product / system belonging to this description may only be handled by personnel qualified for the respective task. This is done taking into account the descriptions associated with the particular task, especially the safety and warning information contained therein.

Due to their training and experience, qualified personnel are able to recognize risks and avoid possible hazards when dealing with this product / system.

Installation and commissioning



⚠ WARNING!

Danger posed by faulty installation and initial commissioning

The installation and initial commissioning of the device must be always performed by trained specialist personnel with sufficient experience. Mistakes during installation may lead to potentially fatal situations or considerable material damage.

- Have installation and initial commissioning carried out only by employees of the manufacturer or by trained personnel authorised by it.
- Have work on electrical components carried out by qualified electricians or persons instructed and supervised by a qualified electrician in accordance with the electrical engineering regulations.
- Whenever working on the device, disconnect it from the power supply and secure it against being switched on again.
- Prior to commissioning, make sure that all safety equipment is installed and functioning properly.

Electrical work



⚠ WARNING!

Danger to life from electrical current!

Contact with live parts poses an immediate danger to life.

Touching open terminals and wires can result in death or serious injury.

- Only have work on electrical components or operating equipment carried out by a qualified electrician.
- De-energise system parts to work on them.
- Check that all exposed components are de-energised before carrying out any work.
- Check that exposed system components are de-energised before carrying out any work on them.
- Do not open any covers during operation.
- Only carry out work on live parts under the supervision of a second person. The supervisor must be able to operate the emergency stop button or main switch in the event of an emergency.
- Some components of the device may still be live even after the system has been switched off. Be sure to follow the notes on their label when working on these components!
- Only use voltage-insulated tools.
- The device must be fitted with protective earth (PE) if connected directly to the mains.

Operation and maintenance



⚠ WARNING!

Injury hazard from insufficient qualification!

Improper handling can cause substantial bodily harm or material damage.

- Only allow the device to be operated and maintained by trained and instructed personnel.
- Only have work on electrical components carried out by a qualified electrician.

3.7 Special hazards

Electrical current



⚠ WARNING!

Live parts

Contact with live parts poses an immediate danger to life. The damage to the insulation or individual components can be life-threatening.

- In case of damage to the insulation, turn off the power supply immediately.
- Check the devices and connected components regularly. Immediately rectify any loose connections, damaged cables and insulations as well as all damage that could pose a risk to safety. Immediately rectify any faulty protection against accidental contact.
- Work on electrical components may only be carried out by qualified electricians or persons instructed and supervised by a qualified electrician in accordance with the electrical engineering regulations.
- Before working on the device, disconnect it from the power supply and secure it against being switched on again.
- Only use voltage-insulated tools.

Electromagnetic field



⚠ WARNING!

Electromagnetic fields

Death or serious injuries

Electromagnetic fields can affect and interfere with pacemakers and defibrillators.

- If you carry a pacemaker, keep sufficient distance.
- Warn people wearing pacemakers before they get close.

3.8 Safety devices



⚠ WARNING!

Danger to life from non-functioning safety devices!

- Check the safety devices before starting work.
- Report faulty safety equipment.
- Have faulty safety equipment repaired.

4 Wireless Charger WC 3.0 - system overview

The wireless charger is a charging system with inductive energy transmission for contactless charging of batteries in AGVs.

The system is intended for industrial applications. Areas of application include unmanned transport systems in intralogistics, mobile robot applications and other automotive applications.

4.1 Components

The charging system is divided into stationary components, which form the primary side of the system, and mobile components, which form the secondary side of the system.

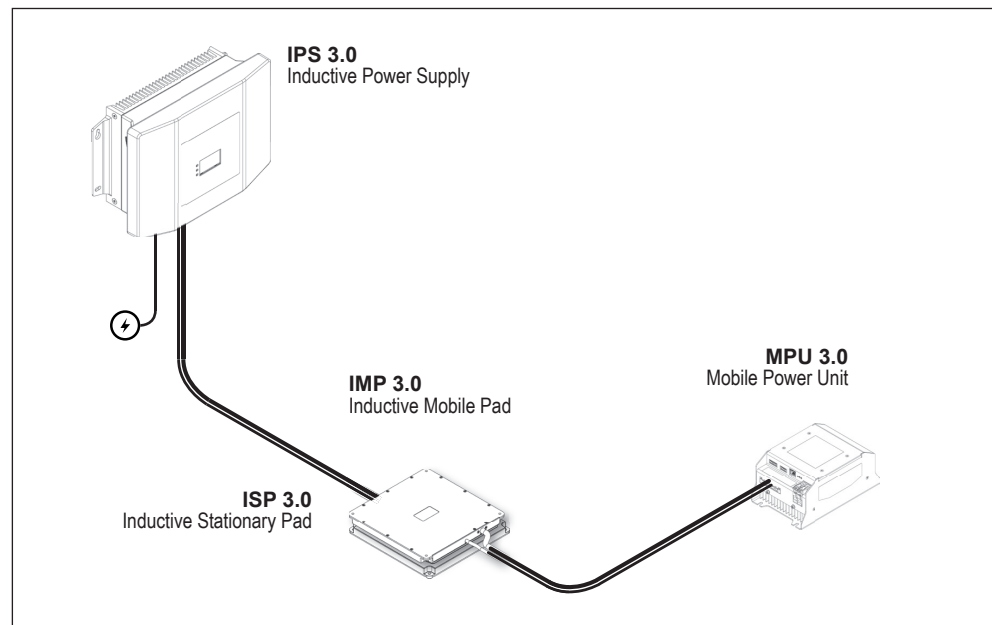

Fig. 1: WC 3.0 components (schematic representation)

Stationary components:

- Stationary power supply
IPS 3.0 - Inductive Power Supply
- Stationary charging pad
ISP 3.0 - Inductive Stationary Pad

Mobile components:

- Mobile charging pad
ISP 3.0 - Inductive Mobile Pad
- Mobile power supply
MPU 3.0 - Mobile Power Unit

4.2 How it works

How it works Charging is possible as soon as the mobile and stationary pad are positioned within a tolerance range of each other.

The charging process starts:

- Immediately in the *[Manual/Continuous]* configuration.
- or by the battery management system
- or by the system controller
- or by the mobile control unit (e.g. vehicle control system)

The charging process ends:

- at the command of the mobile control unit
- or at the command of the battery management system
- or at the command of the system controller
- or when the charging current falls below a specified level
- or when the vehicle is removed from its charging position *



*** Remove the vehicle from its charging position**

If the pads are removed from each other during a charging process, the system detects it as an error state. The charging process will be aborted with an error message.



End-of-charge voltage

If the charging process is not terminated by the software, the charging current is regulated down when the preset end-of-charge voltage is reached, but it is not switched off.



Automatic positioning

The pads cannot detect their position in relation to each other. Only the quality of the data signal is evaluated. The charging process can only be started if the signal is sufficiently stable.

Optimal positioning must be achieved by using suitable external equipment.

4.3 Control circuit

Control circuit The illustration shows the control circuit for inductive power transmission control.

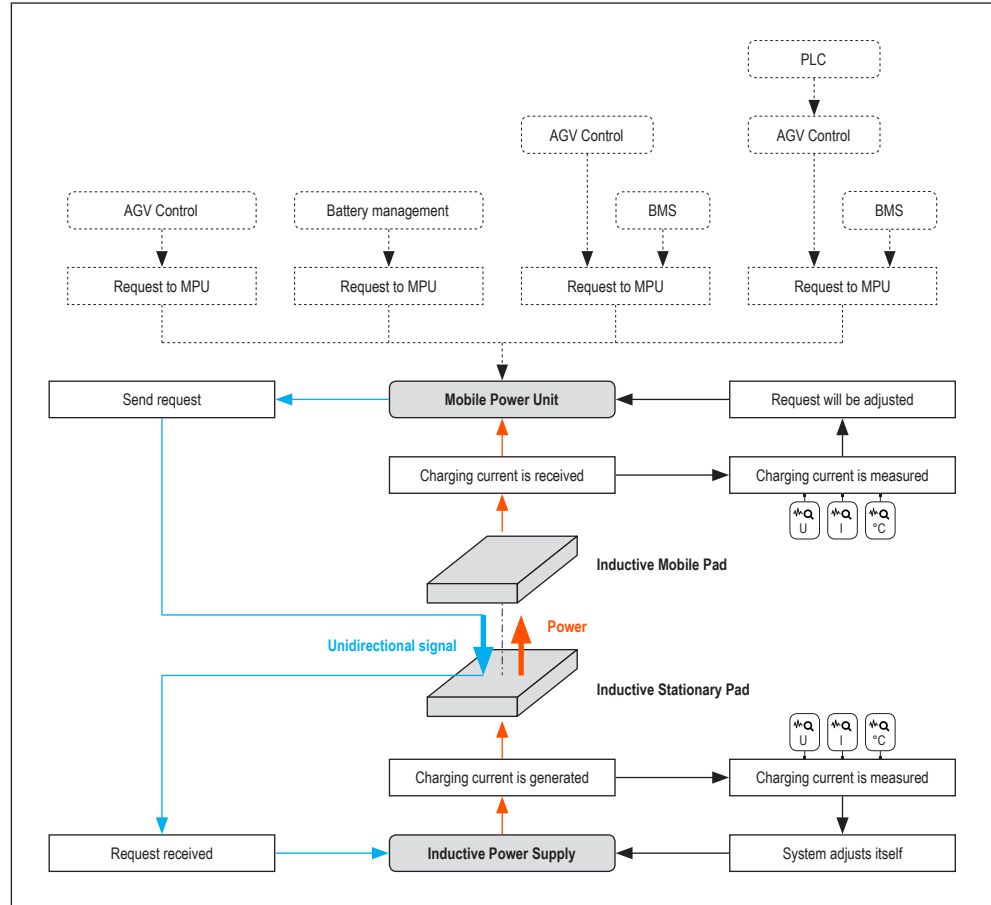

Fig. 2: Control circuit (simplified representation without external enabling processes at the IPS)

The MPU sends a request to the IPS via the pads to start the charging current. The request can be sent permanently or triggered by a control unit overriding the MPU.

The charging current starts as soon as the IPS receives the command and when all external enabling devices (safety switch or similar) are also enabled. The amount of charging current is specified by the MPU.

The MPU adjusts the demand from all external requests along with the measurands, such as voltage, current, temperature.

4.4 Controlling the charging process

The charging process is controlled according to 2 methods:

- Continuous charging
- Controlled charging

Continuous charging

Charging is continuous from switch-on to switch-off using preset values.

The charging current is adjusted by the MPU during the charging process. The adjustment is made depending on previously set specifications and taking measurands such as voltage, current and temperature into account.

Controlled charging

In this mode, the charging current is adjusted during the charging process. The charging process is controlled from switch-on to switch-off by a controller (BMS or AGV controller) upstream of the MPU and controlled by commands to the MPU.

Charging process controlled by:

- Battery management system and system controller
- Battery management system only
- System controller only
- AGV controller or similar only

	Continuous charging mode	Controlled charging mode, controlled by:			
		BMS	BMS+PLC	PLC	AGV controller
Communication	without	CAN	CAN+Ethernet	Ethernet	Ethernet
Condition for start	without	BMS enabling device=1	BMS enabling device=1 and Start by PLC	Start by PLC	Start by AGV controller
Condition to stop	Set voltage / current reached	BMS enabling device=0	BMS enabling device=0 or Stop by PLC	Stop by PLC	Stop by AGV controller
External enabling device	On	On	On	On	On
Start-stop switch	On	On	On	On	On
MPU settings	Settings via web server	Settings via BMS commands and defaults	Settings via BMS/PLC commands and defaults	Settings via PLC commands and defaults	Settings via AGV commands and defaults
Application	Automatic modes		PLC managed modes		
	non-communicating batteries & demos	for batteries with CAN communication	BMS-based charging adapted by the PLC	AGV controller-based charging	AGV controller-based charging
Batteries without communication	yes	no	no	yes	

4.4.1 Charging process - Continuous

Overview

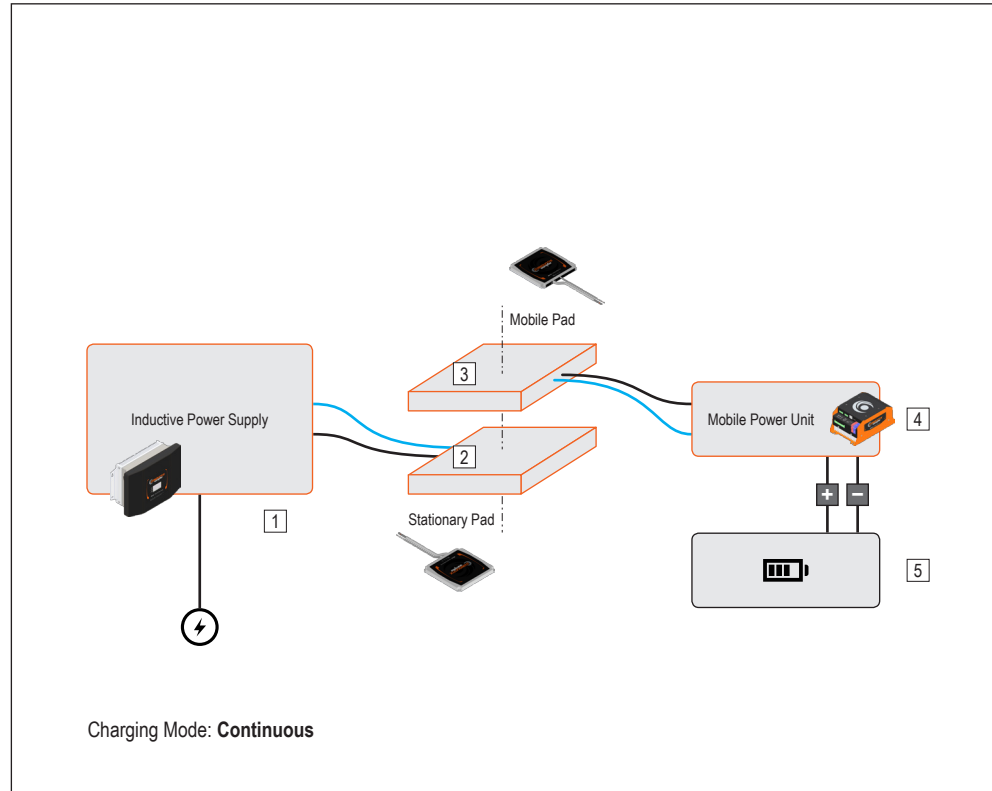

Fig. 3

- 1 IPS - Inductive Power Supply
- 2 ISP - Inductive Stationary Pad
- 3 IMP - Inductive Mobile Pad (AGV)
- 4 MPU - Mobile Power Unit (AGV)
- 5 Battery (AGV)

4.4.2 Charging process - controlled by BMS controller

Overview

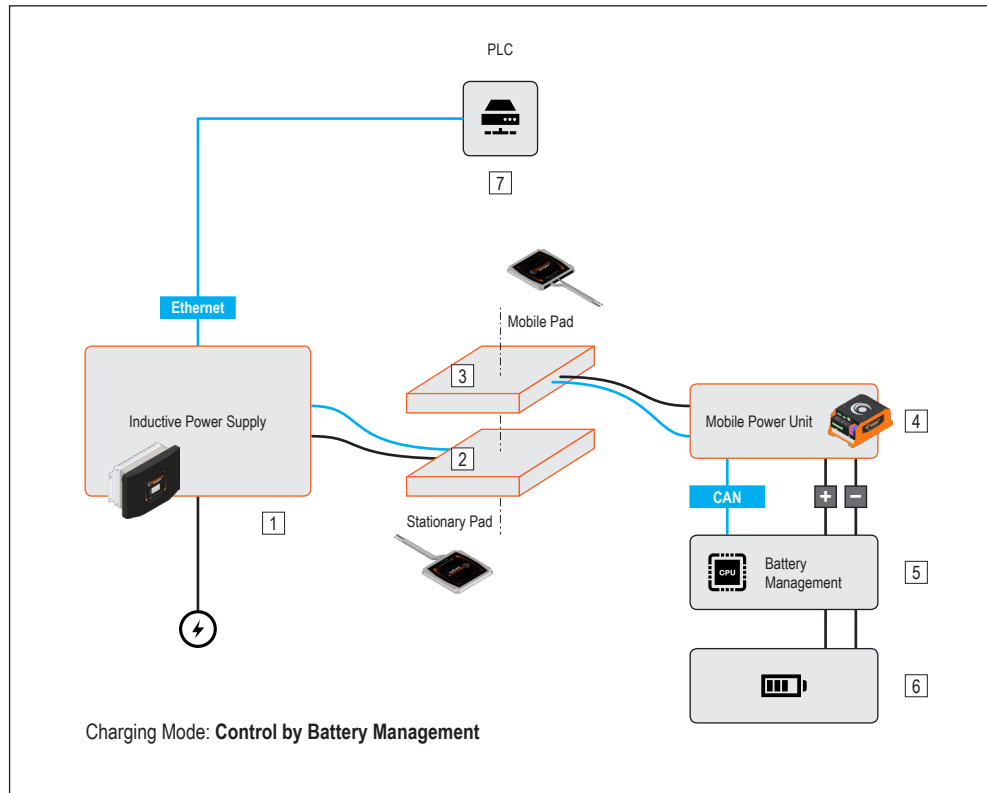

Fig. 4

- 1 IPS - Inductive Power Supply
- 2 ISP - Inductive Stationary Pad
- 3 IMP - Inductive Mobile Pad (AGV)
- 4 MPU - Mobile Power Unit (AGV)
- 5 Battery management (AGV)
- 6 Battery (AGV)
- 7 PLC

4.4.3 Charging process - controlled by BMS and PLC

Overview

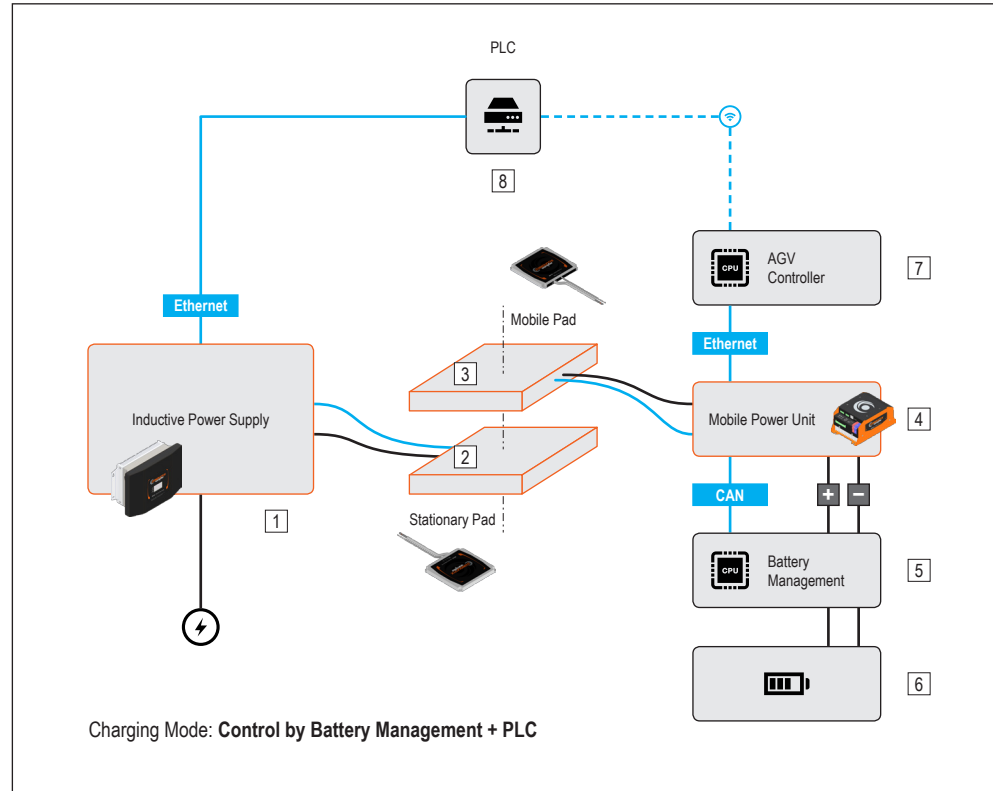

Fig. 5

- 1 IPS - Inductive Power Supply
- 2 ISP - Inductive Stationary Pad
- 3 IMP - Inductive Mobile Pad (AGV)
- 4 MPU - Mobile Power Unit (AGV)
- 5 Battery management (AGV)
- 6 Battery (AGV)
- 7 Vehicle control (AGV)
- 8 PLC

4.4.4 Charging process - controlled by PLC

Overview

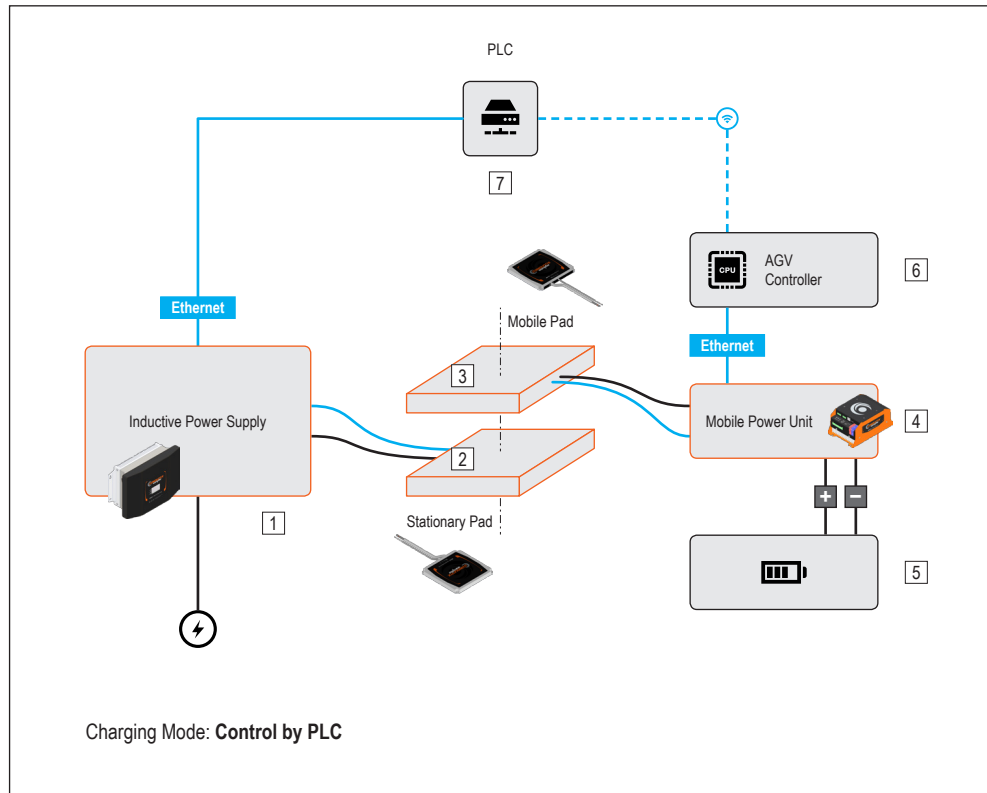

Fig. 6

- 1 IPS - Inductive Power Supply
- 2 ISP - Inductive Stationary Pad
- 3 IMP - Inductive Mobile Pad (AGV)
- 4 MPU - Mobile Power Unit (AGV)
- 5 Battery (AGV)
- 6 Vehicle control (AGV)
- 7 PLC

4.4.5 Charging process - controlled by AGV controller

Overview

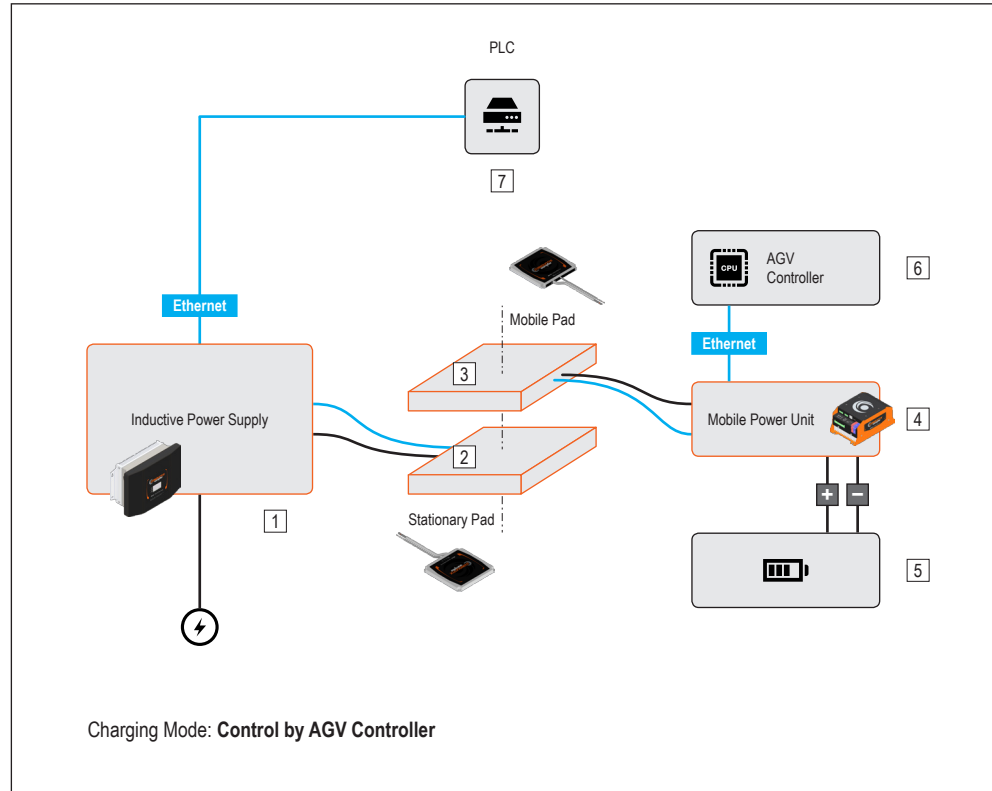

Fig. 7

- 1 IPS - Inductive Power Supply
- 2 ISP - Inductive Stationary Pad
- 3 IMP - Inductive Mobile Pad (AGV)
- 4 MPU - Mobile Power Unit (AGV)
- 5 Battery (AGV)
- 6 Vehicle control (AGV)
- 7 PLC

4.5 Enable commands for charging process

It is possible to combine the start of the charging process at the IPS with defined enable commands. Depending on the parametrisation, these can be limit switches or similar items or else enable commands from the system controller via Ethernet.

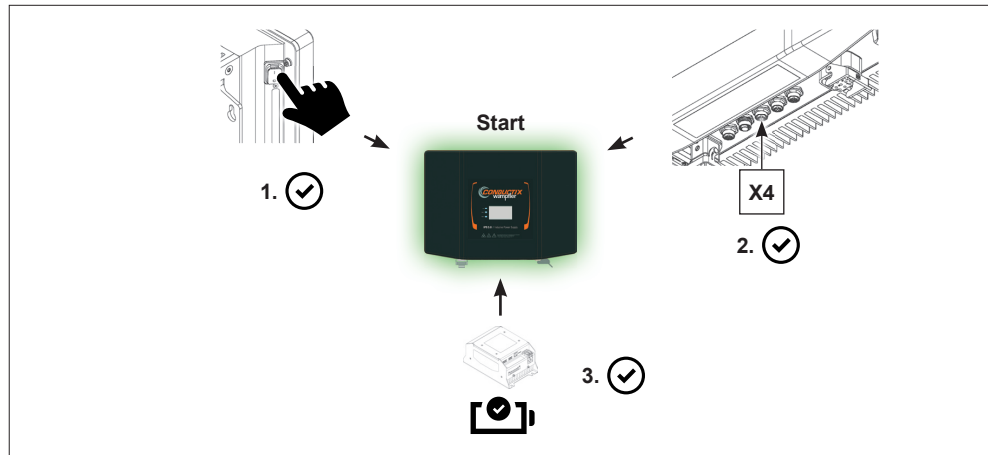

Fig. 8

4.6 Inductive communication

Communication via the pads is unidirectional from the MPU to the IPS. In doing so, the MPU constantly sends a power transfer request.

If the pads are aligned with each other within the tolerances, high signal strength and signal quality ensure continuous communication.

The signal strength deteriorates if the pad positions deviate more from each other. Below a preset threshold, the system evaluates the signal strength as no longer sufficient. The charging process will then be aborted.

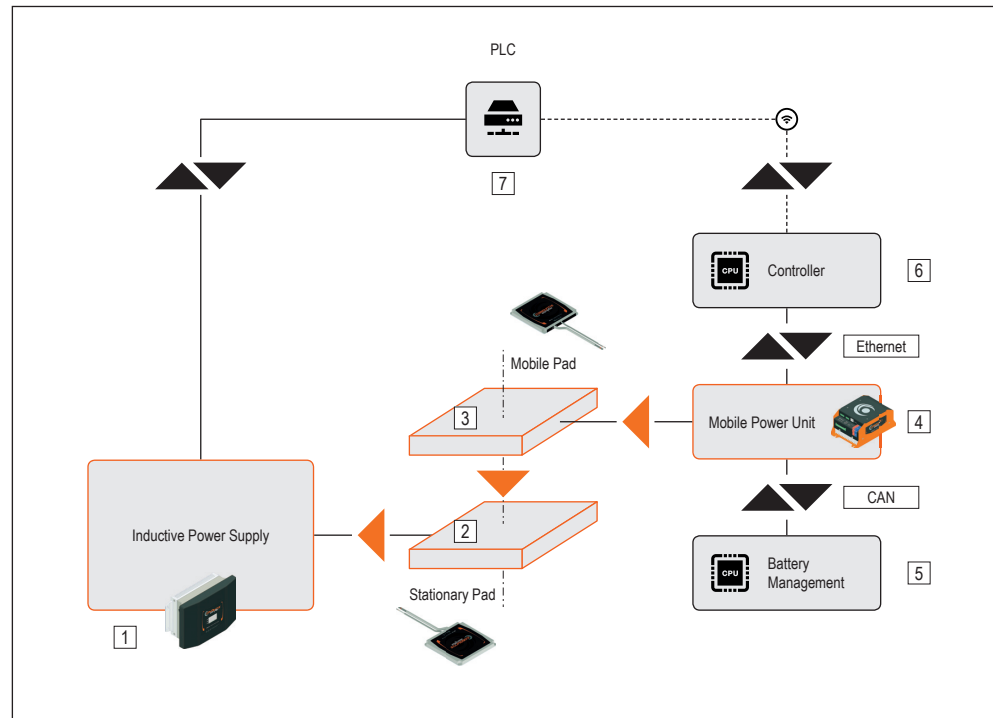

Fig. 9: Inductive communication

- 1 Inductive Power Supply
- 2 Inductive Stationary Pad
- 3 Inductive Mobile Pad (AGV)
- 4 Mobile Power Unit (AGV)
- 5 Battery management (AGV)
- 6 Vehicle control (AGV)
- 7 PLC

5 Product description

5.1 Structure



IMP/ISP - identical in construction

IMP and ISP are identical in construction. The only differences are in the lengths of the supply cables and the connectors.

The charging pad is a coil moulded in a housing.

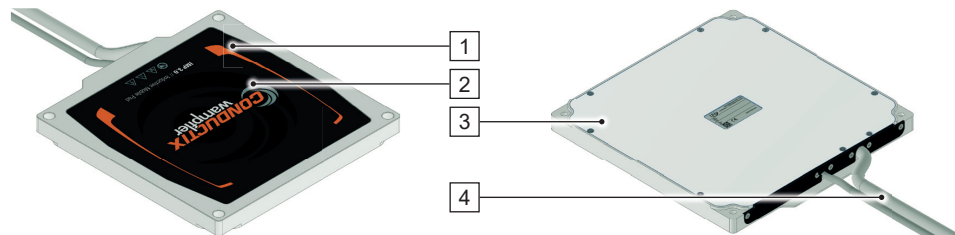

Fig. 10: IMP 3.0/ISP 3.0

- 1 Moulded coil former
- 2 Front side with front film
- 3 Rear side - aluminium assembly plate
- 4 Permanently installed supply cables

5.2 Function

The stationary pad (ISP) and mobile pad (IMP) are identically constructed coil formers and together form a transformer unit.

They are used to transmit power to the AGVs at fixed positions without contact.

As passive components of the inductive system, both components have no setting options.

5.3 Type label

The following figure shows the layout of a device type label.

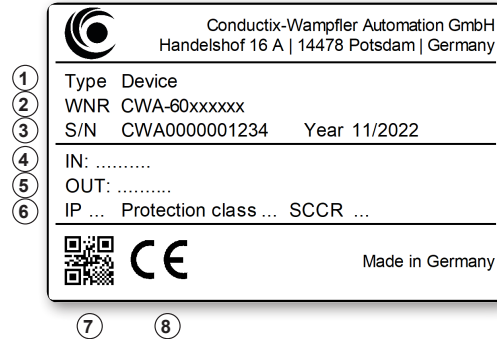

Fig. 11: Device type label

- 1 Model name
- 2 WNR item number
- 3 Serial number, year of construction
- 4 Input data
- 5 Output data
- 6 Protection type, protection class, short-circuit current
- 7 QR-Code (serial number)
- 8 CE marking

5.4 Scope of delivery

5.4.1 Device

ISP 3.0 - Scope of delivery

Name	Item number	WNR	Scope of delivery	Number
ISP 3.0 Inductive Stationary Pad	3267991	CWA-60693001	ISP 3.0 pad with 10 m connection cables	1
			ISP power connector: Han compact with Q8/0-M crimp pin insert	1
			ISP signal connector: Binder M12-A, 4-pin, male, metal, shielded	1
			Folding ferrite for power cable	1

TNB_0073, 5, en_GB

IMP 3.0 - Scope of delivery

Name	Item number	WNR	Scope of delivery	Number
IMP 3.0 Inductive Mobile Pad	3267993	CWA-60693000	IMP 3.0 pad with 1 m connection cables	1
			IMP power connector: Phoenix circuit board connector, 6-pin GMSTB 2.5 HCV/ 6-ST-7.62-LR	1
			IMP signal connector: Phoenix circuit board connector, 5-pin MC 1.5/ 5-ST-3.81	1

5.4.2 Product sets**WCS 3.0 - Scope of delivery**

Name	Item number	WNR	Scope of delivery	Number
WCS 3.0 Set Wireless Charger Stationary Set	3289517	CWA-60690001	IPS 3.0 Inductive Power Supply	1
			ISP 3.0 Inductive Stationary Pad	1

WCM 3.0 - Scope of delivery

Name	Item number	WNR	Scope of delivery	Number
WCM 3.0 Set Wireless Charger Mobile Set	3276340	CWA-60690000	MPU 3.0 Mobile Power Unit	1
			IMP 3.0 Inductive Mobile Pad	1

6 Transport and storage

6.1 Transport



NOTICE!

Transport

Incorrect or improper transport may cause damage to the device.

- Only trained personnel are allowed to transport the device.
- If necessary, use suitable transport aids.
- Transport the devices with utmost care.
- Observe the symbols on the packaging.
- Do not remove packaging and transport securing devices until you are ready to start with the installation.

6.2 Transport inspection

Check the delivery for completeness and transport damage upon receipt.

Proceed as follows in case of any apparent damage:

- Refuse to accept the delivery or accept it only conditionally. Take note of the extent of the damage and write it down on the carrier's transport documents or delivery note.
- Initiate a complaints process and report the incident to the supplier. If Conductix-Wampfler Automation is your direct supplier you will find our contact information in this document.
↳ *Chapter 'Customer service and addresses' on page 73*



Claims for damages

Claim any defect as soon as it becomes apparent. Damages can only be claimed within the applicable claim periods.

6.3 Storage



NOTICE!

Storage

Incorrect or improper storage may cause damage to the device.

- Cover connections with protective caps during storage.
- Avoid mechanical stress and vibrations.
- Store in a dry and dust-free location.
- Regularly check the condition of the stored device.
- Keep environmental conditions as specified in the technical information.
- Keep the storage temperature as specified in the technical information.

7 Mechanical installation

Objective	This section provides details on the mechanical installation. Electrical installation is possible following successful mechanical installation.
Responsible party	<p>The system integrator (e.g. system builder, operator) is responsible for trouble-free and safe installation. As the contact person, he responds to all the fitter's queries regarding safe-to-use equipment; e.g.:</p> <ul style="list-style-type: none">■ Fire protection■ Electrical equipment■ Ladders and scaffolding■ Requirements for assembly tools■ Lifting and transportation
Required personnel	<p>Due to their training and experience, only qualified and appropriately instructed personnel are able to correctly assess the respective initial situation, identify risks and avoid hazards.</p> <p>Personnel required for installation:</p> <ul style="list-style-type: none">■ Adequately qualified fitter
Required personal protective equipment	<p>The person responsible must ensure that the personnel under his responsibility are wearing the required personal protective equipment. The required personal protective equipment satisfies the requirements for the work to be carried out and all the requirements demanded by the scope of work.</p> <p>Personal protective equipment that fulfils its intended purpose:</p> <ul style="list-style-type: none">■ protects its wearer from injury;■ reduces the seriousness and severity of potential injuries. <p>Wear:</p> <ul style="list-style-type: none">■ Work protection clothing■ Safety shoes■ Protective gloves■ Protective goggles
Safety in the work area	<ul style="list-style-type: none">■ Note the safety signs in the area around the system.■ Pay attention to the safety notes in additional applicable documentation (supplier documents).

**Work safety**

Pay attention to company and task-specific work safety regulations, as well as the country-specific legal and safety regulations applicable at the location of use.

**Wear additional protective equipment**

As an employee, you wear protective equipment supplied by the area supervisor. If work tasks have been delegated only temporarily, then you also wear any protective equipment that has become additionally required.

Special hazards**⚠ WARNING!****Live parts**

Contact with live parts poses an immediate danger to life.

- Disconnect the power supply of the device before mechanically and electrically installing the device.
- Take the necessary measures to ensure that the power supply of the device cannot be switched on again unintentionally.

7.1 Installation location and position



⚠ WARNING!

Marking of electrically inductive component

Being an electrically inductive component, the device must be visibly installed or visibly marked at all times.

- Mark the location and position of the device with suitable markings or warnings.

ISP - Inductive Stationary Pad

The ISP is intended for fixed assembly on a solid base or a support.

The following factors should be considered for the assembly location:

- Sufficient air circulation.
- Walkways and driveways.
Note: The pad can only be walked on! You cannot drive on it!
- Cable routes.
Note: Lay cables in such a way that they are not mechanically stressed. Do not walk on or drive over cables.
- Cable length to the IPS
↳ Chapter 'Cable lengths and specifications' on page 71
- Metal-free areas

The ISP can be installed horizontally and vertically. The arrangement depends on the mechanical positioning of the IMP mobile pad installed on the AGV.

The printed part is the front side of the pad. It must face the IMP when in operation.

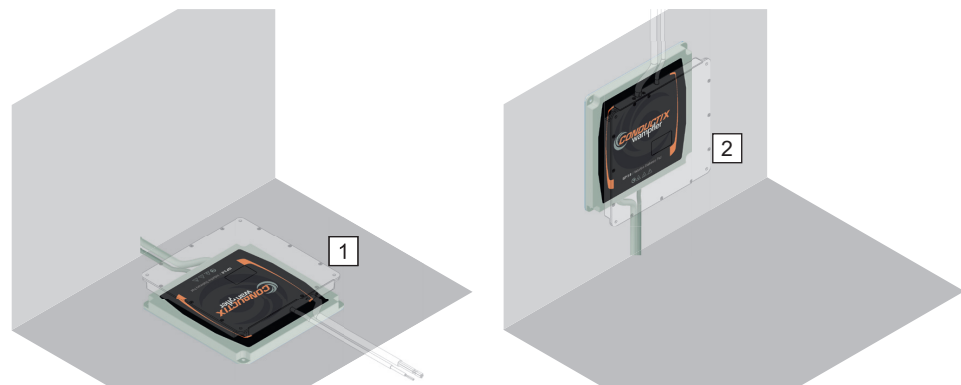

Fig. 12: ISP installation position

- 1 Horizontal installation position
- 2 Vertical installation position

IMP - Inductive Mobile Pad

The IMP is designed to be assembled on a mobile unit (e.g. AGV).

The following factors should be considered for the assembly location:

- Sufficient air circulation.
- Cable length to the MPU
 - ↳ Chapter 'Cable lengths and specifications' on page 71
- Metal-free areas

The IMP can be installed horizontally and vertically. The arrangement depends on the mechanical positioning of the ISP stationery pad.

The printed part is the front side of the pad. It must face the ISP when in operation.

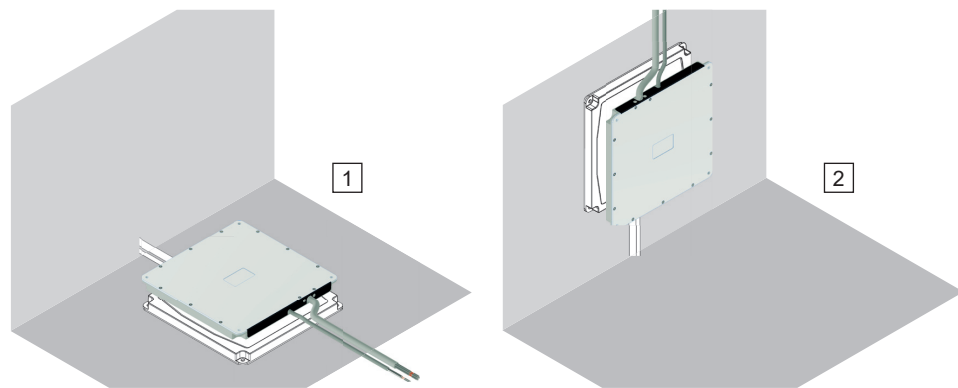

Fig. 13: IMP installation position

- 1 Horizontal installation position
- 2 Vertical installation position

7.2 Open spaces and cooling

No major clearances must be maintained. The pad should be easy to reach and dismantle for maintenance.

Active cooling is not necessary. The heat generated is passively released into the environment.

7.3 Metal-free area

The pads can be assembled directly on metal. The pads are equipped with integrated shielding.

Inductive transmission starts even if the pads are not centred on top of each other. It is allowed for the pads to be offset. (see also [Chapter 'Pad alignment' on page 42](#))

If the pads are offset from each other, part of the effective area is outside the pads. There must be no ferromagnetic components in this area. Therefore, a metal-free area that is specified by the max. permissible offset of the pads (25 mm) must be maintained around the pads.

Data	Value	Unit
Metal-free area (min.)	35	mm

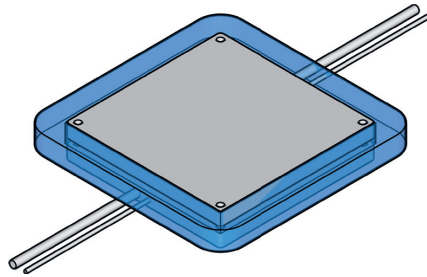

Fig. 14: Metal-free area around the pads (shown in blue)

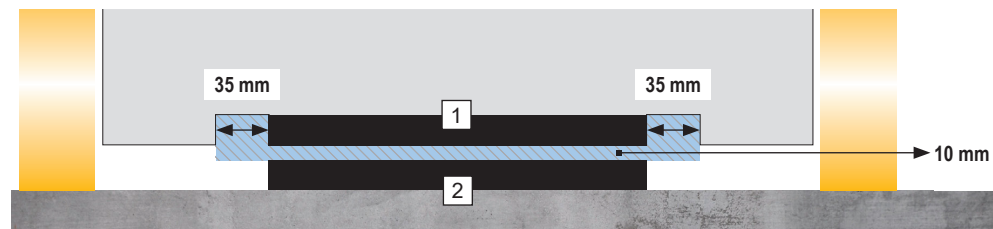

Fig. 15: AGV metal-free area (schematic representation)

- 1 IMP - Inductive Mobile Pad
- 2 ISP - Inductive Stationary Pad



Greater offset of the pads!

A greater offset of the pads to each other can lead to situations that require adjustments for the metal-free area.

- *Coordinate changes with our service.*

7.4 Installation



NOTICE!

Mechanical stress

Incorrect loading can lead to damage or even destruction of the pad.

- The pad may not be used as a load-bearing component.

ISP assembly

There are 4 holes in the main body for fixing the ISP.

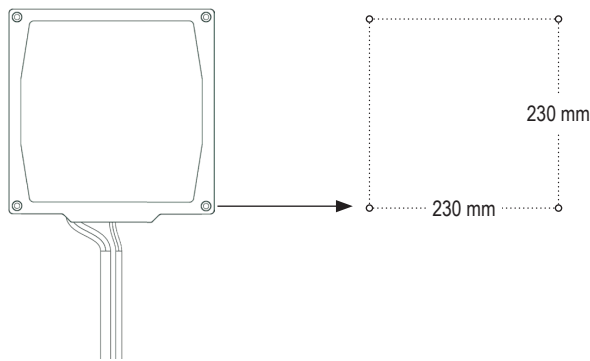

Fig. 16: ISP fixing points

Data	Value	Unit
Hole distance	230	mm
Screws	M6 × 16	
Tightening torque	4	Nm

IMP assembly

There are 4 holes in the main body for fixing the IMP.

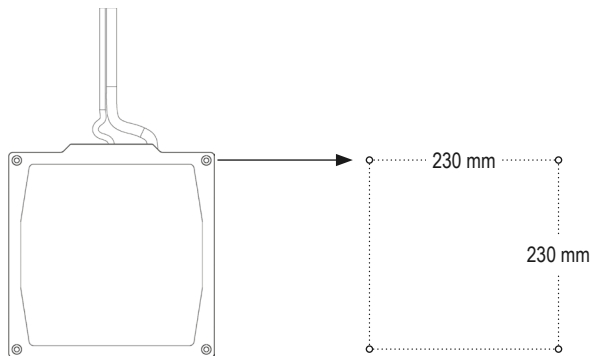

Fig. 17: IMP fixing points

Data	Value	Unit
Hole distance	230	mm
Screws	M6×16	
Tightening torque	4	Nm

**Detailed device drawings**

You will find detailed device drawings in the appendix to this description.

7.5 Pad alignment

For charging to take place, the pads must be positioned in alignment with each other. The position and distance between the pads must be observed.



Automatic positioning

The pads cannot detect their position in relation to each other. Only the quality of the data signal is evaluated. The charging process can only be started if the signal is sufficiently stable.

Optimal positioning must be achieved by using suitable external equipment.

7.5.1 Vertical alignment

The function of the pads is designed for a distance (top edge of ISP ↔ bottom edge of IMP) of 10 ... 40 mm. (Fig. 18)

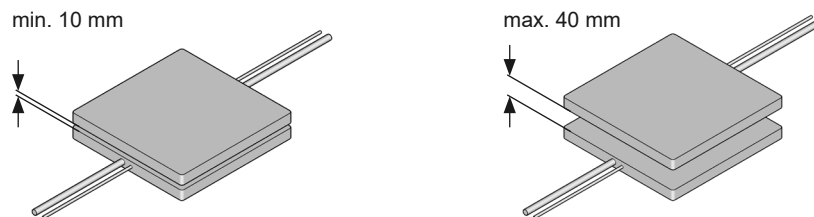

Fig. 18: Distance between the pads

Data	Value	Unit
Minimum distance	10	mm
Maximum distance	40	mm

7.5.2 Horizontal alignment

The function of the pads is also designed for lateral offset of the pads.

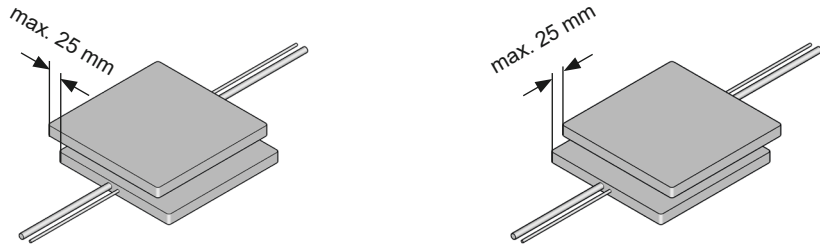

Fig. 19

Data	Value	Unit
Maximum offset (x, y)	25	mm



Offset >25 mm

In the event of a larger offset, the system can continue to maintain operation. However, stable operation can only be guaranteed up to an offset of 25 mm.

7.5.3 Radial alignment

The pads may only be positioned at 0° or 180° to each other. (Fig. 20)

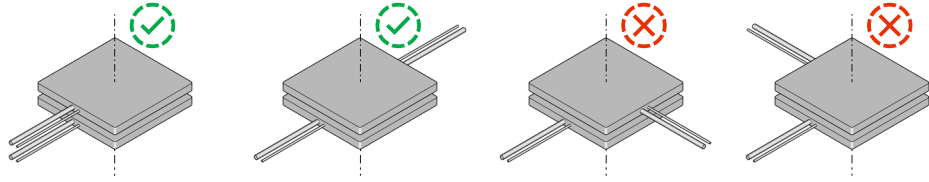

Fig. 20

The pads can be radially offset from each other up to a maximum angle. The maximum angle is related to the horizontal distance between the pads (Fig. 21). The greater the distance, the greater the possible radial offset.

A lateral offset is not considered here.

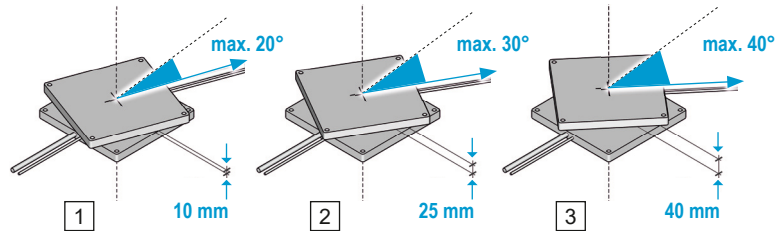

Fig. 21

- 1 Radial offset at 10 mm distance
- 2 Radial offset at 25 mm distance
- 3 Radial offset at 40 mm distance

Data	Value	Unit
Maximum radial angle Distance of the pads = 10 mm	20	°
Maximum radial angle Distance of the pads = 40 mm	40	°

7.5.4 Working range



Stable 3 kW power

If the pads are aligned with each other within the maximum deviation (working range), the continuous power transmission is guaranteed.

Deviations from the working range lead to power losses and can cause system failures.

The working range includes the space of permissible horizontal and vertical deviations of the pads. If the pads are within the working boundaries of each other, the full range of functions is guaranteed.

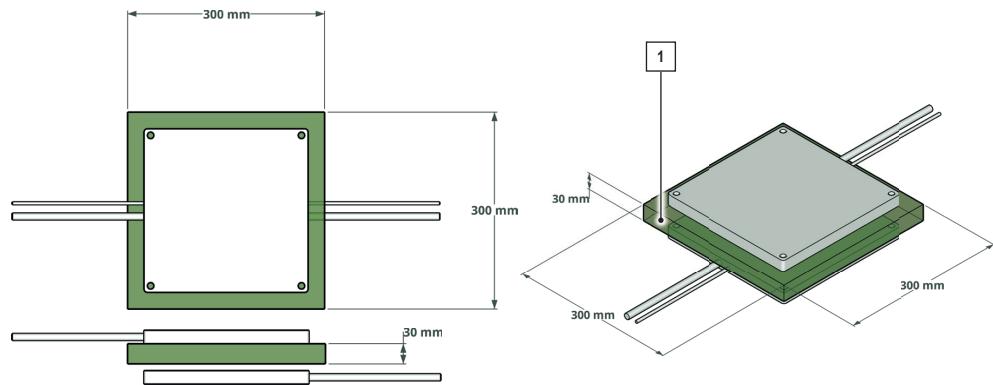

Fig. 22: Working range

1 Working range (coloured)

The tolerance range for the mechanical positioning of the equipment carrier (e.g. AGV) should be within the working range of the pads.



Control of the charging process

The control of the charging process is set to the defined working range. The system constantly readjusts the control during the transmission process.

If the pads are outside the working range, the system continues to readjust the control within its physical limits. As soon as the communication is interrupted, the charging process is stopped.

8 Electrical installation

Objective	This section provides details on the electrical installation. Commissioning is possible following successful electrical installation.
Responsible party	<p>The system integrator (e.g. system builder, operator) is responsible for trouble-free and safe electrical installation. As the contact person, he responds to all the fitter's queries regarding safe-to-use equipment; e.g.:</p> <ul style="list-style-type: none"> ■ Fire protection ■ Electrical equipment ■ Ladders and scaffolding ■ Requirements for assembly tools
Required personnel	<p>Due to their training and experience, only qualified and appropriately instructed personnel are able to correctly assess the respective initial situation, identify risks and avoid hazards.</p> <p>Personnel required for electrical installation:</p> <ul style="list-style-type: none"> ■ Qualified electrician ■ Adequately qualified fitter under the direction and supervision of a qualified electrician
Required personal protective equipment	<p>The person responsible must ensure that the personnel under his responsibility are wearing the required personal protective equipment. The required personal protective equipment satisfies the requirements for the work to be carried out and all the requirements demanded by the scope of work.</p> <p>Personal protective equipment that fulfils its intended purpose:</p> <ul style="list-style-type: none"> ■ protects its wearer from injury; ■ reduces the seriousness and severity of potential injuries. <p>Wear:</p> <ul style="list-style-type: none"> ■ Work protection clothing ■ Safety shoes ■ Protective gloves ■ Protective goggles
Safety in the work area	<ul style="list-style-type: none"> ■ Note the safety signs in the area around the system. ■ Pay attention to the safety notes in additional applicable documentation (supplier documents).

**Work safety**

Pay attention to company and task-specific work safety regulations, as well as the country-specific legal and safety regulations applicable at the location of use.

**Wear additional protective equipment**

As an employee, you wear protective equipment supplied by the area supervisor. If work tasks have been delegated only temporarily, then you also wear any protective equipment that has become additionally required.

Special hazards**⚠ WARNING!****Live parts**

Contact with live parts poses an immediate danger to life.

- Disconnect the power supply of the device before mechanically and electrically installing the device.
- Take the necessary measures to ensure that the power supply of the device cannot be switched on again unintentionally.

8.1 Cable routing

The following points apply when laying the connection cables for the pads:

- Power and data cables can be laid together. Fig. 23
- Multiple power cables should be laid separately due to heat generation. Fig. 24
- Lay cables in such a way that they are not mechanically stressed. Do not walk on or drive over cables!
- Observe the bending radii of the cables.

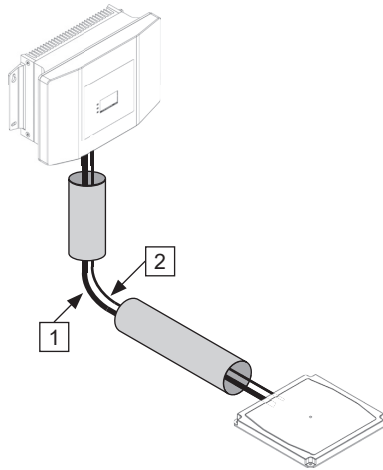

Fig. 23: Joint laying of power and data cables

- 1 Power cable
- 2 Data cable

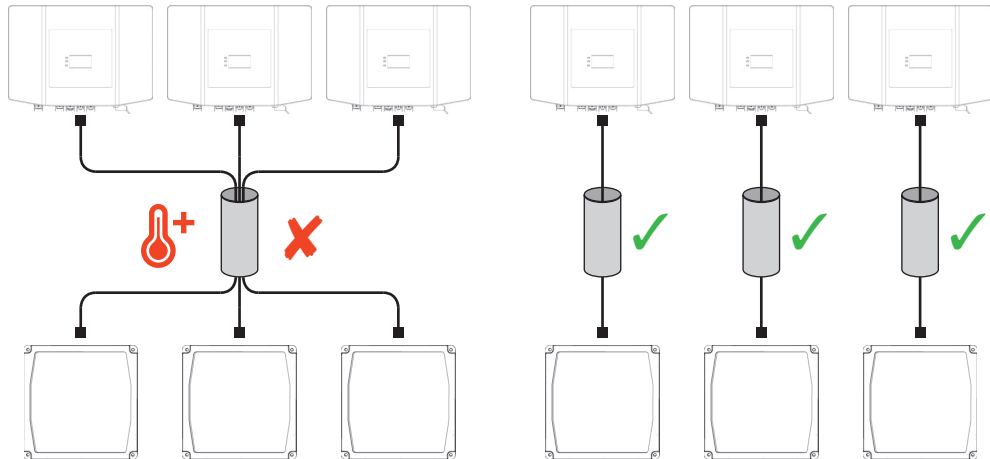

Fig. 24: Separate laying of power cables

Power cable - temperature development during operation

During operation, the power cable heats up.

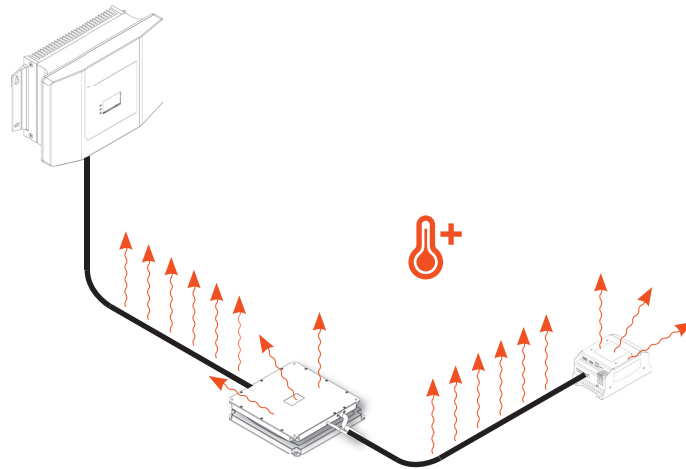

Fig. 25: Temperature development on power cable during operation

Data	Value	Unit
Power cable temperature rating *	80	°C

* Permissible maximum temperature at the copper surface of the cores



NOTICE!

Temperature development during operation

During operation, the power cable heats up. If the passive heat dissipation of the cable is restricted, it could lead to damage to the cable.

- Allow passive heat dissipation to the environment.
- Use suitable brackets/clips for cables.
- Keep heat-sensitive materials away.
- When using cable ducts, prevent heat build-up.

8.1.1 Laying cables in the ground

If the pipes are laid in the ground, ensure that the heat can be sufficiently dissipated.

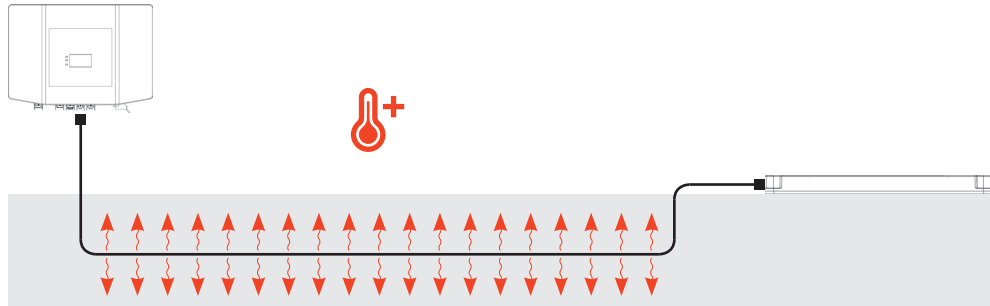

Fig. 26

The installation depth depends on the local conditions and the requirements for ground load.

8.1.2 Laying cables in a cable duct

If cables are laid in cable ducts, the maximum permissible temperatures must be observed.

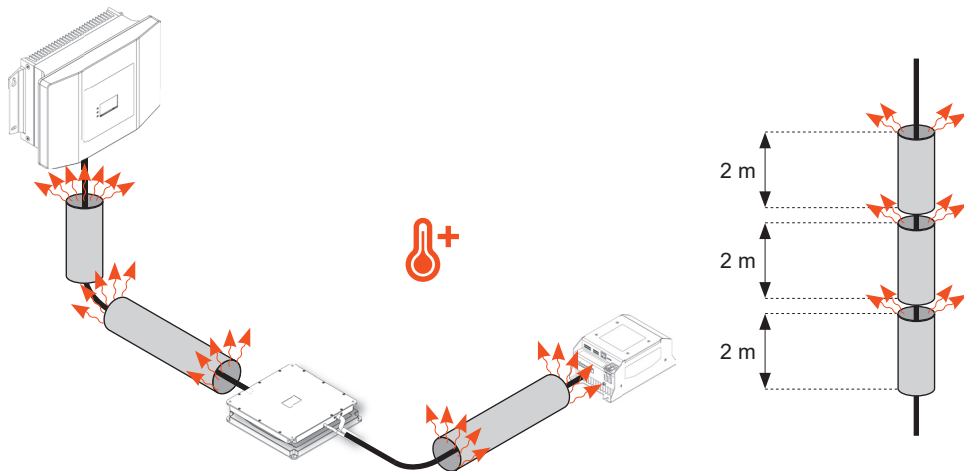

Fig. 27

Data	Value	Unit
Recommended length of individual cable ducts	2	m

Example

The following drawing (Fig. 28) shows the measurement of the temperature inside a horizontally laid cable duct.

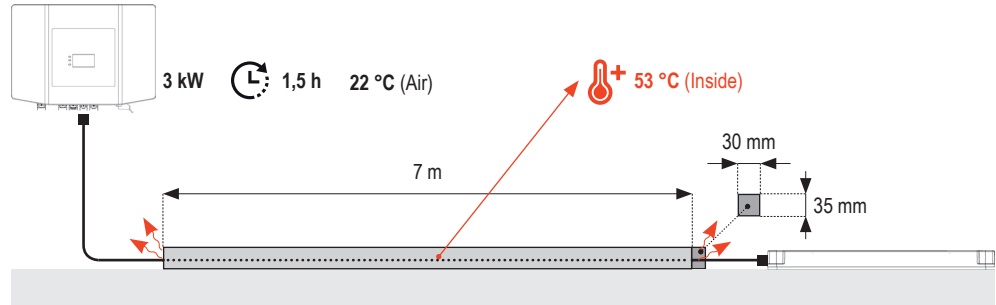

Fig. 28: (Drawing not to scale)

Data	Value	Unit
Cable duct length	7	m
Cable duct (W×H)	30×35	mm
Transmitted power	3	kW
Time of measurement after:	1.5	h
Ambient temperature	22	°C
Temperature measured in the cable duct	53	°C

At a maximum permissible ambient temperature of 45 °C, this would put the temperature just below the permissible limit of 80 °C.

NOTICE!



Maximum temperature

It is recommended to test the temperature of the cable in marginal conditions.

Example

The following drawing (Fig. 29) shows the measurement of the temperature inside a horizontally or vertically laid cable duct. The ends of the cable duct are plugged.

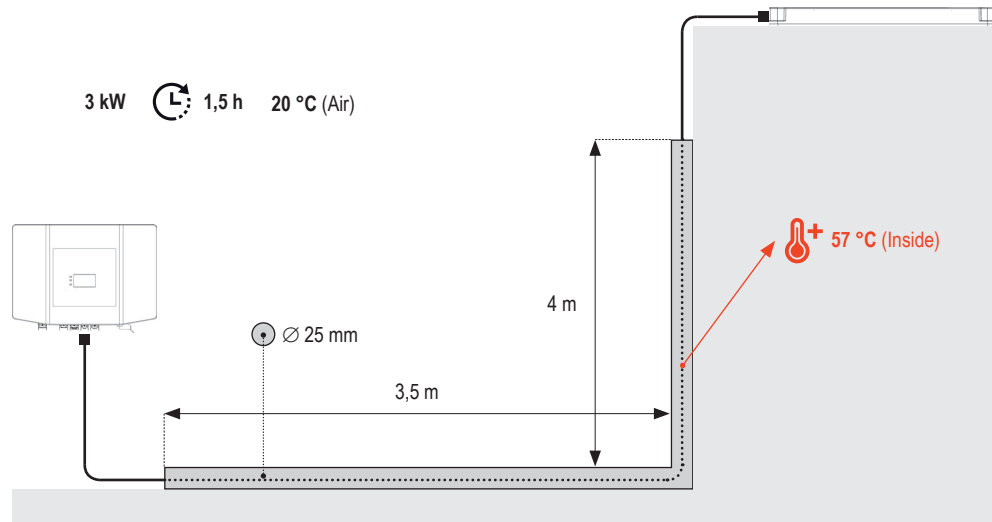

Fig. 29: (Drawing not to scale)

Data	Value	Unit
Cable duct horizontal length	3.5	m
Cable duct vertical length	4	m
Cable duct diameter	25	mm
Transmitted power	3	kW
Time of measurement after:	1.5	h
Ambient temperature	20	°C
Temperature measured in the cable duct	57	°C

At a maximum permissible ambient temperature of 45 °C, this would put the temperature just above the permissible limit of 80 °C.

NOTICE!**Maximum temperature**

It is recommended to test the temperature of the cable in marginal conditions.

8.1.3 Shortening cables

**Shortening cables**

The data and power cables installed on the IMP and ISP can be shortened, but must not be extended. System adjustments are not necessary for this.

8.2 Electrical connection of the pads



Detailed connection diagrams

Below you will find a compact overview of the individual connections and their pin assignment.

You will find detailed connection diagrams in the appendix to this description.

ISP - Electrical connection

Connect the Inductive Stationary Pad (ISP) as follows:

1. Connect the supplied power connector to the power cable of the ISP.
2. Assemble the folding ferrite on the power cable of the ISP.
Max. Distance to the connector: 10 cm
3. Connect the supplied power connector to the data cable of the ISP.
4. Connect the connectors to the Inductive Power Supply IPS.
 - Connect the power connector to X7 of the IPS.
 - Connect the signal connector to X6 of the IPS.

Pin assignment - ISP power connector

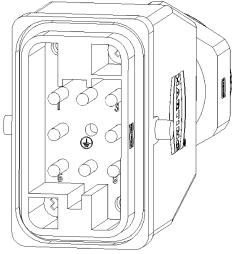
Connector type	Connector image	Pin	Signal	Connection
Harting Han compact with Q8/0-M crimp male insert (supplied)		1	AC1	Individual wire 1
		2	AC2	Individual wire 2
		3	AC1	Individual wire 3
		4	AC2	Individual wire 4
		5	AC1	Individual wire 5
		6	AC2	Individual wire 6
		7	Br+	Bridge in connector 1 x 0.75 mm ² BK
		8	Br-	

Pin assignment - ISP signal connector

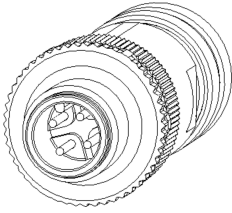
Connector type	Connector image	Pin	Signal	Connection
Binder M12-A, 4-pin, male, metal, shielded (supplied)		1	Target+	Green individual wire
		2	target-	Yellow individual wire
		3	GND	White individual wire
		4	L_T	Brown individual wire
		SH	SH	Shielding

IMP - Electrical connection

Connect the Inductive Mobile Pad (IMP) as follows:

1. Connect the supplied power connector to the power cable of the IMP.
2. Connect the supplied power connector to the data cable of the IMP.
3. Connect the connectors to the Inductive Mobile Unit MPU.
 - Connect the power connector to X1 of the MPU.
 - Connect the signal connector to X2 of the MPU.

Pin assignment - IMP power connector

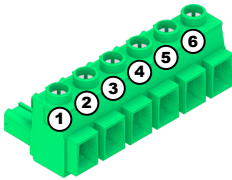
Phoenix GMSTB 2.5 HCV/ 6-ST-7.62-LR (supplied)		Pin	Signal	Connection
		1	AC1	Individual wire 1
		2	AC2	Individual wire 2
		3	AC1	Individual wire 3
		4	AC2	Individual wire 4
		5	AC1	Individual wire 5
		6	AC2	Individual wire 6

Pin assignment - IMP signal connector

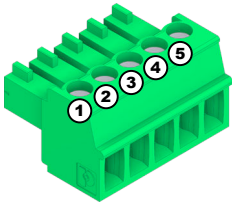
Phoenix MC 1.5/5-ST-3.81 (supplied)		Pin	Signal	Connection
		1	FB-	Green individual wire
		2	FB+	Yellow individual wire
		3	SH	Shielding
		4	GND	White individual wire
		5	Temp	Brown individual wire

8.3 Floor conductivity

Electrostatic discharge

Industrial trucks can become statically charged in operation. Electrostatic discharge on the industrial trucks may cause damage to the system components.

Electrostatic discharge is to be prevented by means of appropriate technical measures.

- Conductive wheels
- Discharge brushes
- Discharge strips
- ESD-conductive connections on the vehicle

Dissipative floor

Static charging can be reduced or prevented by an electrically conductive coating of the floor.

The earthing resistance of the floor should comply with the specifications of DIN EN 61340-5-1. (Electrostatics – Part 5–1: Protection of electronic devices from electrostatic phenomena – General requirements)



NOTICE!

Ferromagnetic components in the coating

The electrically conductive coating must not contain any ferromagnetic components in the immediate vicinity of the pads.

- Possible influence on the inductive system.
- Possible damage due to intense heating.

9 Commissioning

ISP and IMP are supplied and controlled via the connected devices.

After proper mechanical and electrical installation, the pads are ready for operation with the connected devices.

10 Operation

10.1 Electromagnetic field

When charging is active, the stationary pad generates an electromagnetic field.

When charging is active, an alternating magnetic field is created between the pads. The intensity of the magnetic field emanating from the edges was tested by a certified laboratory in accordance with the **DIN EN 62311:2008-09** standard (*Assessment of electronic and electrical equipment related to human exposure restrictions for electromagnetic fields (0 Hz - 300 GHz)*).

Radiation field measurement

The magnetic field is measured at the outer edges of the charging pads. Here, the pads are considered as one common object for measurement purposes. (Fig. 30)

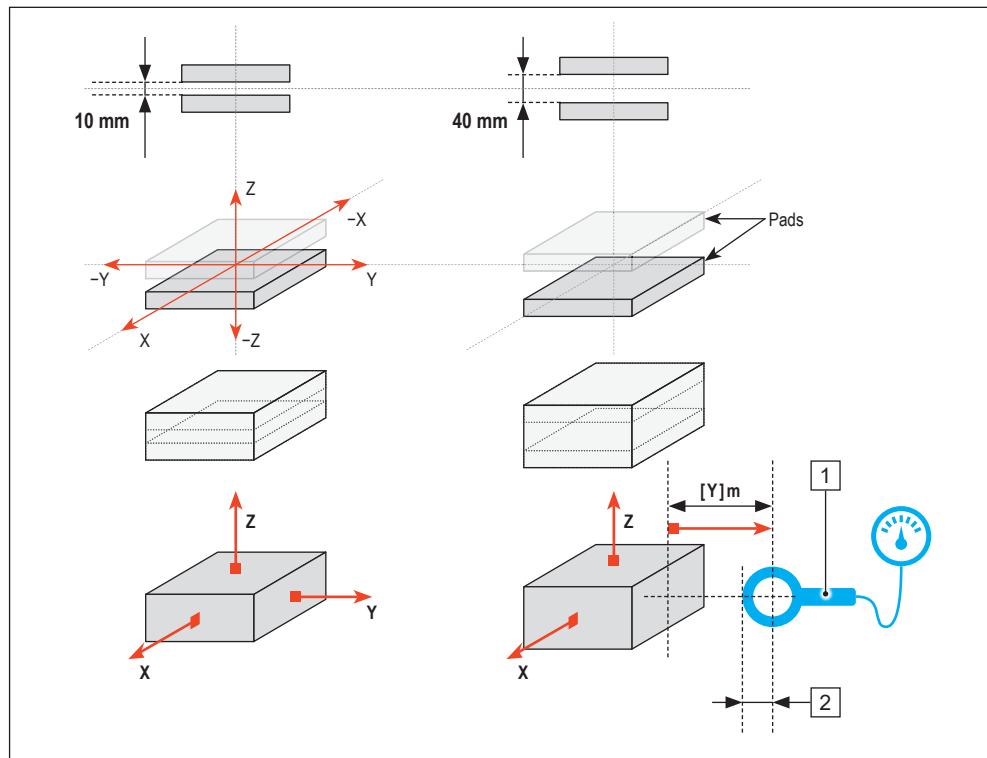

Fig. 30

- 1 Measuring probe
- 2 Minimum distance for the measurement is limited by the design of the measuring probe

Results of the magnetic field measurement

Outside the following minimum distances from the outer surfaces of the pad arrangement, the alternating magnetic fields are safely below the occupational exposure limit values (exposure time of 6 min) according to the 1998 ICNIRP guideline.

Test result 85 kHz / Distance of Pads = 40 mm

Measuring position	Measuring distance (clearance) [m]	Measuring value [A/m]	Limit value [A/m] ¹⁾
laterally from the pads	0.11	18.8	18.8
Rear sides	0.06 ²⁾	12.3	18.8

Test result 130 kHz / Distance of Pads = 10 mm

Measuring position	Measuring distance (clearance) [m]	Measuring value [A/m]	Limit value [A/m] *
laterally from the pads	0.06 ²⁾	10.9	12.3
Rear sides	0.06 ²⁾	4.8	12.3

¹⁾ Reference value of the magnetic field strength in the relevant frequency range $H [A/m] = 1.6 / f [MHz]$

²⁾ Due to the design of the measuring probe, it was not possible to measure a distance smaller than 0.06 m.

Reference values

The following values are an extract from the reference value table of the standard listed above. They represent the guideline values to be complied with.

Table - Reference values for occupational exposure to time-varying electric and magnetic fields

Data	Value	Unit
Frequency range	0.1 - 1	MHz
Electric field strength	610	Vm ¹
Magnetic field strength	1.6/f	Am ¹
B-field	2.0/f	µT
Averaging time	6*	min

TNB_0073, 5, en_GB

* S, E2, H2 and B2 are averaged over six minutes per period for frequencies between 100 kHz and 10 GHz. S, E2, H2 and B2 are to be averaged over an arbitrary period of $68/f \cdot 1.05$ minutes (f in GHz) for frequencies above 10 GHz.

Marginal ranges

Representation of the limit range according to the permissible limit values based on the measured values (Fig. 31):

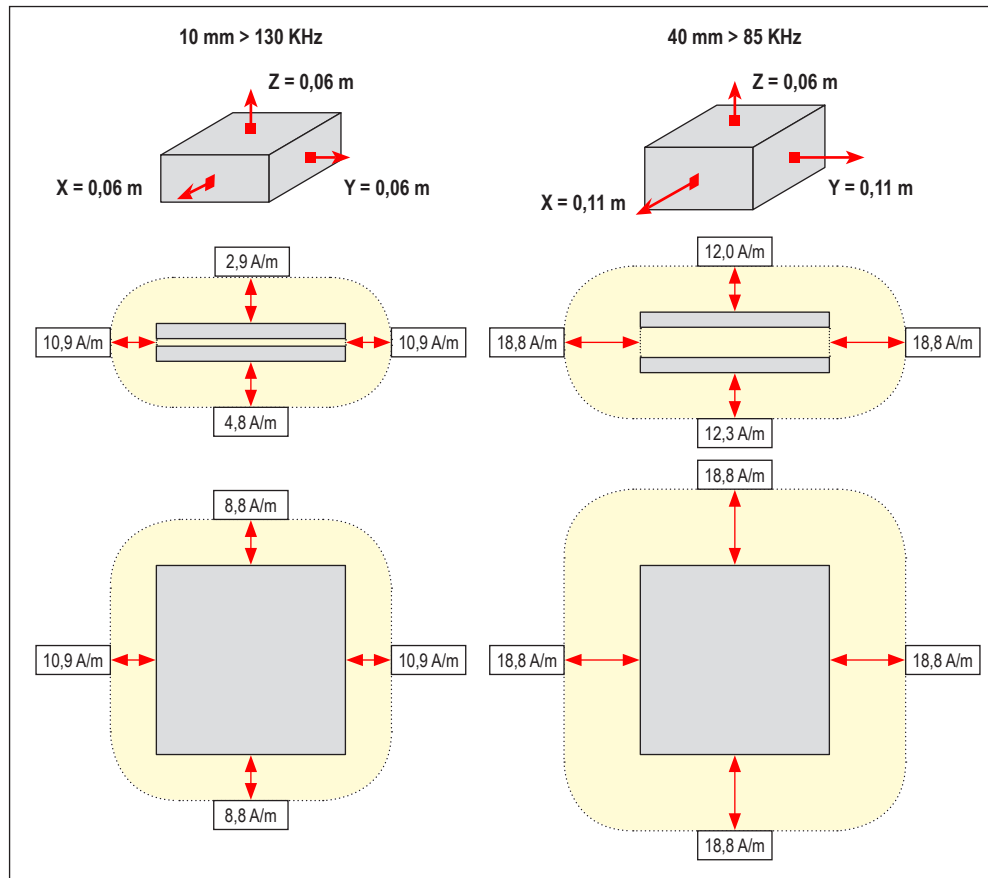

Fig. 31

Conclusion

To comply with the occupational exposure limit values (exposure time of 6 min) according to the 1998 ICNIRP guideline, the following distances from the pads must be observed:

Pad distance:	10 mm	40 mm
Working frequency:	130 kHz	85 kHz
Distance to the top	0.06 m	0.06 m
Lateral distance	0.06 m	0.11 m
Distance to the bottom	0.06 m	0.06 m

10.2 Charging process

10.2.1 Automatic adjustment of the primary current

The control of the charging process is divided between the MPU and the IPS. The MPU determines a primary current requirement from the target/ actual values of the charging voltage and charging current and transmits this to the IPS. The IPS controls the level of the primary current with the self-determined optimal frequency.

During the start-up phase, the system controls itself up to the maximum charging power.

Data	Value	Unit
Power transmission ▶ Start	5	s
Power transmission ▶ 100 %	Max. 30	s

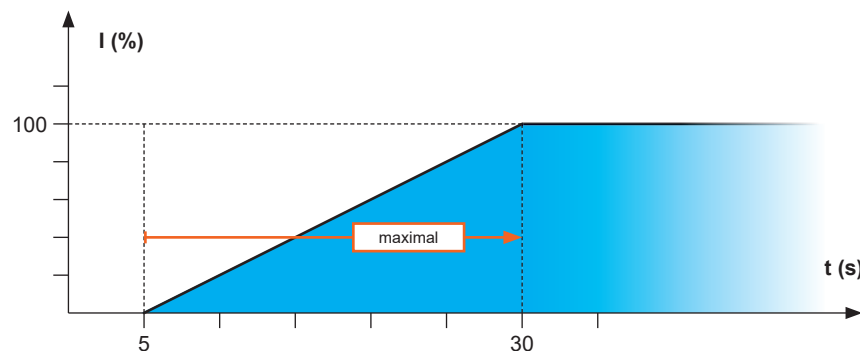

Fig. 32: Time until maximum charging power

10.2.2 Temperature generation during the charging process

All system components are equipped with temperature controls. The temperatures at the heat sinks and the coils of the pads are detected and evaluated.

A warning message is output when the temperatures are above normal. A fault message is displayed if the temperatures are too high.

If the temperatures in the warning messages on one of the components are exceeded, the charging current is reduced (derating). If the temperature continues to rise despite reduced charging current, the charging process will be aborted. A fault message is output.

ISP temperature control

Data	Value	Unit
Warning message <ul style="list-style-type: none"> ▶ High temperature at coil ▶ Charging current will be reduced 	80	°C
Fault message <ul style="list-style-type: none"> ▶ Temperature too high at coil ▶ Charging process will be aborted 	85	°C

IMP temperature control

Data	Value	Unit
Warning message <ul style="list-style-type: none"> ▶ High temperature at coil ▶ Charging current will be reduced 	80	°C
Fault message <ul style="list-style-type: none"> ▶ Temperature too high at coil ▶ Charging process will be aborted 	85	°C

10.2.3 Power reduction with temperature increase

Derating

During the charging process, all connected components heat up. The heating depends on the operating time, the transmitted power, the charging current and the installation conditions (possibility of heat dissipation).

All components are assigned a maximum temperature in the respective configuration settings. If this temperature is exceeded in the event of an error, the charging process is switched off and an error message is displayed.

The charging process is prevented from stopping due to overtemperature by means of derating. The power gets reduced already at a temperature value below the maximum.

For every K of temperature increase above the warning value, the output is reduced by 20 %.

Charging process switch-off due to overtemperature is excluded by a linear reduction of the permissible maximum current from a warning threshold that is 5 K below the limit temperature.

Temperature		Power reduction	Maximum current
$[T_{max}] - 5 \text{ K}$	Warning		60 A
$[T_{max}] - 4 \text{ K}$	Warning	20 %	48 A
$[T_{max}] - 3 \text{ K}$	Warning	40 %	36 A
$[T_{max}] - 2 \text{ K}$	Warning	60 %	24 A
$[T_{max}] - 1 \text{ K}$	Warning	80 %	12 A
$[T_{max}] - 0 \text{ K}$	Error Charging process switch-off	100 %	0 A

10.2.4 Power reduction in case of pad displacement



Stable 3 kW power

If the pads are aligned with each other within the maximum deviation (working range), the continuous power transmission is guaranteed.

Deviations from the working range lead to power losses and can cause system failures.

11 Faults

Faults at the pads are detected and output by the connected devices (IPS, MPU). This essentially refers to the detection of the coil temperature.

12 Maintenance and cleaning

Personnel

Maintenance, cleaning and servicing must only be performed by trained and qualified personnel. Personnel who are to be trained or instructed are only allowed to perform activities under the constant supervision of a trained and qualified individual.



⚠ WARNING!

Danger to life from electrical current!

Contact with live parts poses an immediate danger to life.

- Disconnect the system from the power supply and secure it against being switched on again before servicing and cleaning the device.



⚠ WARNING!

Foreign bodies catching fire

The surfaces of the pads must be protected from contamination. Conductive and electromagnetic foreign bodies can heat up during the charging process and catch fire on the surface.

- Check and clean the surfaces regularly.
- Prevent contamination by taking appropriate measures.

12.1 Maintenance



NOTICE!

Mechanical loads may lead to device failure.

- Check the device for damage at regular intervals.
- Opening the device for testing purposes is not intended.

Service the device as follows:

- **Brackets**
 - Check for loose connections.
- **Connections**
 - Check for loose connections.
 - Check cable insulation.
 - Cover any ports not being used.
- **Indicators**
 - Remove soiling.
- **Recommended maintenance interval**
 - 6 months

12.2 Cleaning



NOTICE!

Damage to the device due to improper cleaning

- Do not use any cleaning agents, such as methylated spirits, or other cleaners!
- Do not clean with sharp objects!

Clean the device as follows:

- **Device**
 - Clean with dry cloths only.
- **Recommended cleaning intervals**
 - 6 months

13 Information on disposal and environmental regulations

If no return or disposal agreements exist, the individual components are to be properly dismantled and then separated and disposed of pursuant to current regulations or taken for recycling.

The device comprises electric and electronic components. Separate and dispose of them according to applicable provisions.

Follow the hazardous materials directive, in particular the regulations on handling hazardous materials.

 Materials designated for recycling are to be disposed of as per the respective recycling procedure.

14 Technical Data

14.1 Dimensions

IMP 3.0 dimensions

Data	Value	Unit
Length	250	mm
Width	250	mm
Height	20	mm

ISP 3.0 dimensions

Data	Value	Unit
Length	250	mm
Width	250	mm
Height	20	mm



Detailed device drawings

You will find detailed device drawings in the appendix to this description.

14.2 Weight

ISP 3.0 weight

Data	Value	Unit
Weight	6500	g

IMP 3.0 weight

Data	Value	Unit
Weight	4250	g

14.3 Material

Material

Data	Value
Base body	Polycaprolactam PA6
Base plate	Aluminium

14.4 Cooling

Data	Value
Cooling	Passive convection

14.5 Load-bearing capacity

Data	Value	Unit
Load-bearing capacity on entire surface	*	kg
Load-bearing capacity per cm ²	*	kg/cm ²



*** load-bearing capacity**

Please contact our service department or your direct contact at Conductix-Wampfler Automation.

NOTICE!



Inductive Stationary Pad load-bearing capacity

The ISP is designed for common and generally foreseeable loads. It should be noted that the pad is considered an electrical component. It is designed for application as an electromagnetic coil former. The aluminium plate on the back carries a ferrite plate with the coil. The coil former seals the housing and is moulded with plastic. For physical reasons, no further stabilisers made of metal or similar can be used inside the coil former.

For the load-bearing capacity of the pad, a load covering the entire surface of the pad must be considered. High point loads must be avoided.

It is also crucial to have an even substrate. Bending or twisting of the pad under load must be excluded.

14.6 Environmental conditions

Environmental conditions

Data	Value	Unit
Constant dry heat DIN IEC 60068-2-2	45	°C

Data	Value	Unit
Constant moist heat (93%) DIN IEC 60068-2-78	40	°C
Cold DIN IEC 60068-2-1	-10	°C
Temperature change DIN IEC 60068-2-14	-10 ... 60	°C
Vibrations 5 ... 8 Hz DIN IEC 60068-2-6:2008	± 7.5	mm
Vibrations 8 ... 150 Hz DIN IEC 60068-2-6:2008	20	m/s ²
Vibrations 10 ... 58 Hz DIN IEC 60068-2-6	± 0.075	mm
Vibrations 58 ... 150 Hz DIN IEC 60068-2-6	10	m/s ²
Shock DIN IEC 60068-2-27	150	m/s ²
Repetitive shocks; storage and transport without packaging DIN IEC 60068-2-27	100	m/s ²
Shocks during operation DIN IEC 60068-2-27	50	m/s ²
Oscillation, broadband noise with tempera- ture change 100 ... 150 Hz DIN IEC 60068-2-53	5.72	m/s ²
Impact DIN IEC 60068-2-75:1997	1	Nm
Free fall in transport packaging DIN IEC 60068-2-31:2008	≤1500	mm
Ambient temperature (non-condensing, no dew formation)	10 ... 45	°C
Storage temperature	10 ... 50	°C
Relative humidity (non-condensing)	≤ 80	%
Cooling	Passive con- vection (active as an option)	
Maximum installation height above sea level	2000	m
Protection class	IP65	

14.7 ISP input data

Data	Value	Unit
Rated power with IPS 3.0/3 kW	3	kW

14.8 IMP output data

Data	Value	Unit
Rated power with MPU 3.0/3 kW	3	kW
Continuous output power	3	kW
Maximum output power	3	kW

14.9 Cable lengths and specifications

	Cable	Cable specifications	Cable length max.	Bending radius fixed installation	Bending radius occasionally moved
ISP	Power cable	LAPP PUR/PP A 6x2.5 BK	10 m	7×Ø	12×Ø
	Data cable	Unitronic FD Li2YCY (TP) A BE 2x2x0.34	10 m	6×Ø	15×Ø
IMP	Power cable	LAPP PUR/PP A 6x2.5 BK	1 m	7×Ø	12×Ø
	Data cable	Unitronic FD Li2YCY (TP) A BE 2x2x0.34	1 m	6×Ø	15×Ø

14.10 Approvals and standards

Conformity	Devices made by Conductix-Wampfler Automation GmbH have been designed to comply with EU directives. Please contact Conductix-Wampfler Automation GmbH if you wish to obtain a copy of the EU Declaration of Conformity.
Standards	<p>The devices and the entire system are tested according to the following standards:</p> <p>Low Voltage Directive</p> <p>DIN EN IEC UL 61010-1 - Safety requirements for electrical equipment for measurement, control, and laboratory use – Part 1: General requirements as a basis for</p> <p>DIN EN IEC 61010-2-201 - Safety requirements for electrical equipment for measurement, control, and laboratory use – Part 2-201: Particular requirements for control equipment</p> <p>DIN EN IEC 62311:2008-09 - Assessment of electronic and electrical equipment related to human exposure restrictions for electromagnetic fields</p> <p>EMC Directive</p> <p>DIN EN IEC 61000-6-2: 2019 - Generic standards – Immunity standard for industrial environments</p> <p>DIN EN IEC 61000-6-4: 2019 - Generic standards – Emission standard for industrial environments</p>

15 Customer service and addresses

Customer service

Our service team is available to provide technical information.

- **Conductix-Wampfler Automation - Service**

Phone: +49 331 887344-15 | Fax: +49 331 887344-19

E-mail: service.potsdam@conductix.com



Service forms

Service forms are available for download under www.conductix.com.

Please send completed service forms to service.potsdam@conductix.com.

Further contacts

Conductix-Wampfler Automation GmbH

Handelshof 16 A | 14478 Potsdam | Germany

Phone: +49 331 887344-0 | Fax: +49 331 887344-19

E-mail: info.potsdam@conductix.com | Internet: www.conductix.com

- **Conductix-Wampfler Automation - Sales**

Phone: +49 331 887344-02 / -04 | Fax: +49 331 887344-19

E-mail: sales.potsdam@conductix.com

- **Conductix-Wampfler Automation - Service**

Phone: +49 331 887344-15 | Fax: +49 331 887344-19

E-mail: service.potsdam@conductix.com

- **Conductix-Wampfler Automation - Repairs**

Phone: +49 331 887344-615 | Fax: +49 331 887344-19

E-mail: repair.potsdam@conductix.com

Conductix-Wampfler GmbH

Rheinstrasse 27 + 33 | 79576 Weil am Rhein | Germany

Phone: +49 7621 662-0 | Fax: +49 7621 662-144

E-mail: info.de@conductix.com | Internet: www.conductix.com

For further addresses of sales and service locations, visit:

- www.conductix.com

16 Index

A

Addresses.....	73
Applicable documents.....	7

C

Cleaning.....	65, 66
Compensation.....	33
Conformity.....	72
Customer service.....	73

D

Damage in transit.....	33
Derating.....	62
DIN EN 61340-5-1.....	56
Dissipative floor.....	56

E

Earthing resistance.....	56
Electrostatic discharge.....	56
ESD.....	56

I

Inductive communication.....	29
------------------------------	----

M

Maintenance.....	65, 66
------------------	--------

P

Personnel.....	14
Pin assignment	
IMP power connector.....	55
IMP signal connector.....	55
ISP power connector.....	54
ISP signal connector.....	54

Power reduction.....	62
----------------------	----

Q

Qualification.....	14
--------------------	----

R

Responsible party	
Electrical installation.....	46
Installation.....	35

S

Safety notes.....	10
Scope of delivery.....	31, 32
Service.....	65
Storage.....	34

T

Transport.....	33
Type label.....	31

W

Warranty.....	9
---------------	---

Appendix

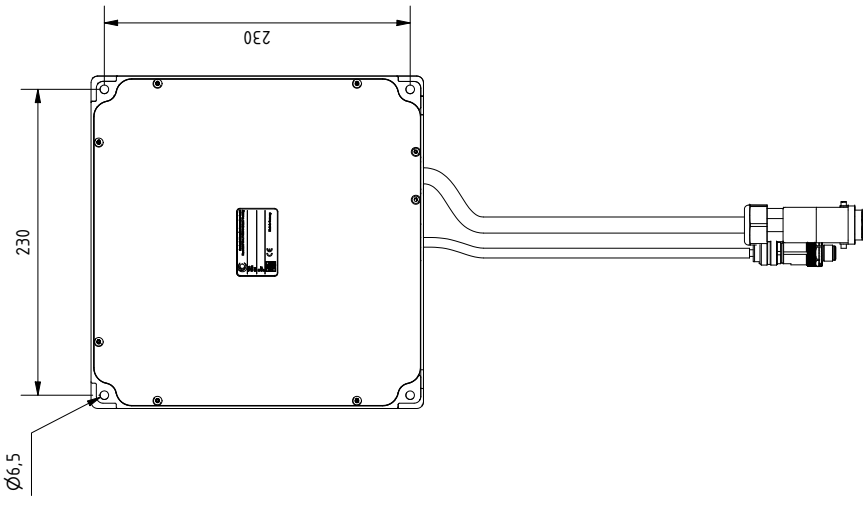
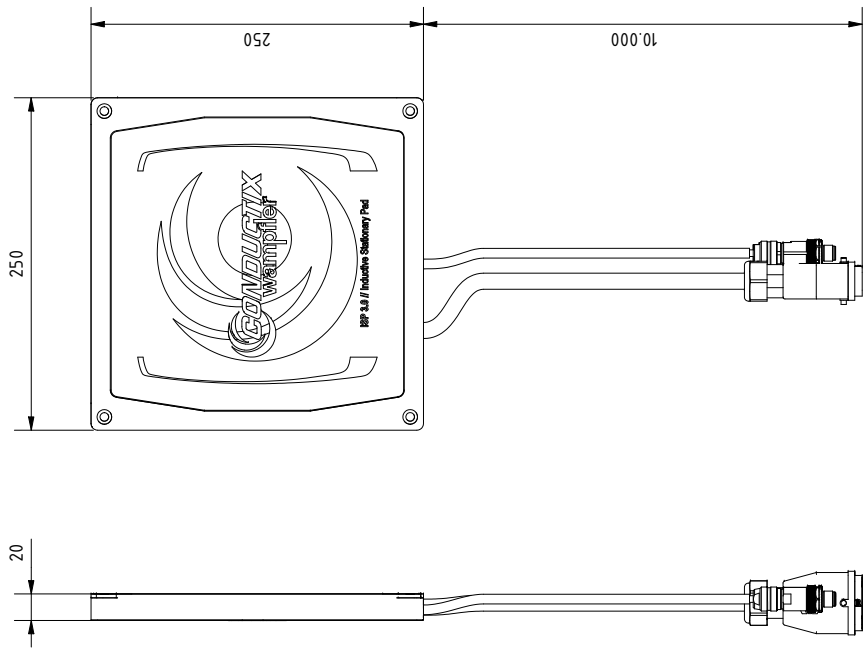
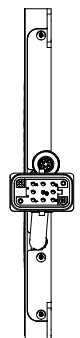

customer /	Conductix-Wampfler Automation GmbH Handelshof 16 A 14.4.78 Potsdam Germany www.conductix.com	drawn by J.Christaller	date of drawing 11.11.2022	pre-series
		edited by	date of editing	
		status of document approved		page 3/3
		material number 3267991		
		title, additional title Inductive Stationary Pad ISP 3.0, 3kW		
		rev. scale P1 1 : 4		format A3

D

C

B

A

D

C

B

A

1 2 3 4 5 6

1 2 3 4 5 6

Conductix-Wampfler Automation GmbH

Handelshof 16 A | 14478 Potsdam | Germany

E-Mail: info.potsdam@conductix.com

Internet: www.conductix.de

Tel.: +49 (0)331 887344-0



End customer CxW-SMO
Location Worldwide
Plant AGV
Product Inductive Stationary Pad
Type ISP 3.0
WNR CWA-60693001
Item Number 3267991

Remarks:

[Connection diagram](#)

created on 01.12.2020

from F.Schleussner

Number of pages

Ind.	Modification	Date	Name	Date		Title page/cover sheet	Index
				orig.	Ed. by		
				Zz.06.2022	F.Schleussner	D	
					H. Ketschut		
					approved		

Title page/cover sheet

End customer
Location
PlantCxW-SMO
Worldwide
AGVProduct
Type
WNRInductive Stationary Pad
ISP 3.0
CWA-60693001

Item Number

3267991

Page

1

-T1
IPS 3.0
LJU-60693001

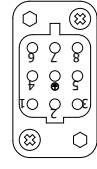

ISP-SIGNAL Plug monitoring

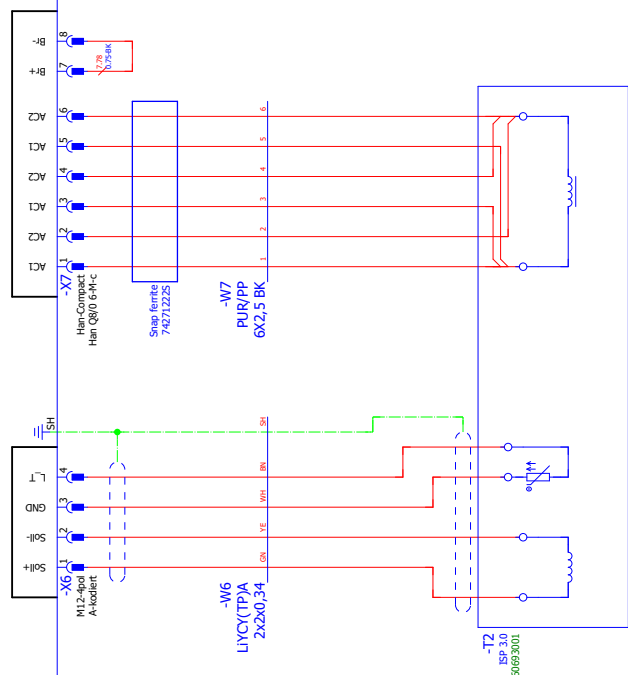



D	Wiring ISP	10.01.2023	H. Ketelhut
C	X6 = M12 + Snap ferrite	22.06.2021	H. Ketelhut
B	Cable W6 Conductors Color changed	28.10.2021	H. Ketelhut
A	Plug X7 Type and Pin assignment changed	06.05.2021	H. Ketelhut
Ind.	Modification	Date	Name
		10.01.2023	H. Ketelhut
		orig.	F.Schleissner
		Ed. by	H. Ketelhut
		Status	approved
		Index	

End customer	CxW-SMO	Product Type	Inductive Stationary Pad
Location	Worldwide	WNR	ISP 3.0
Plant	AGV		CWA-60693001

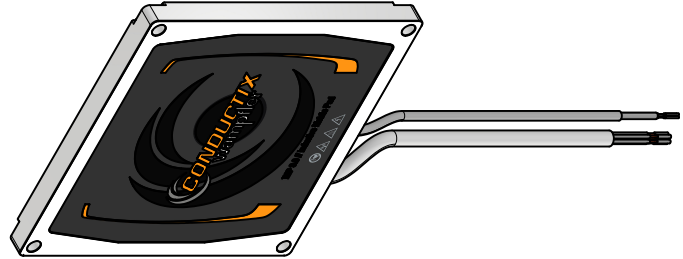
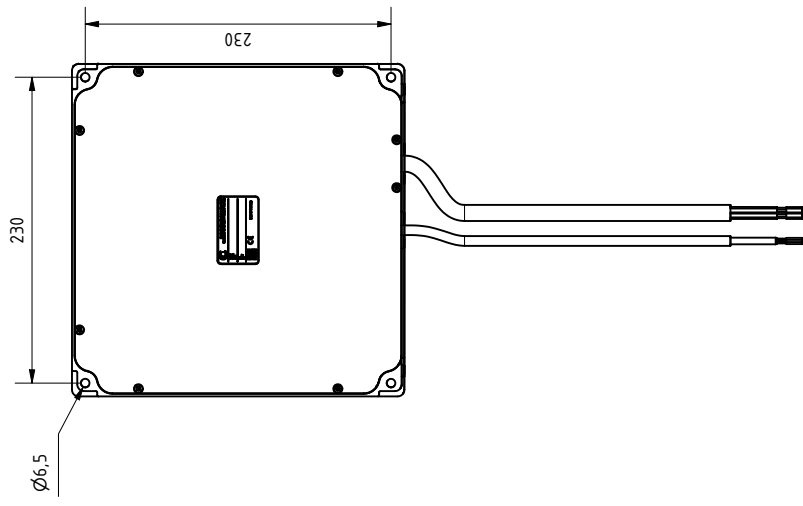
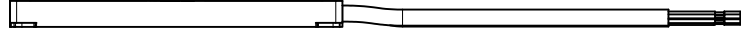
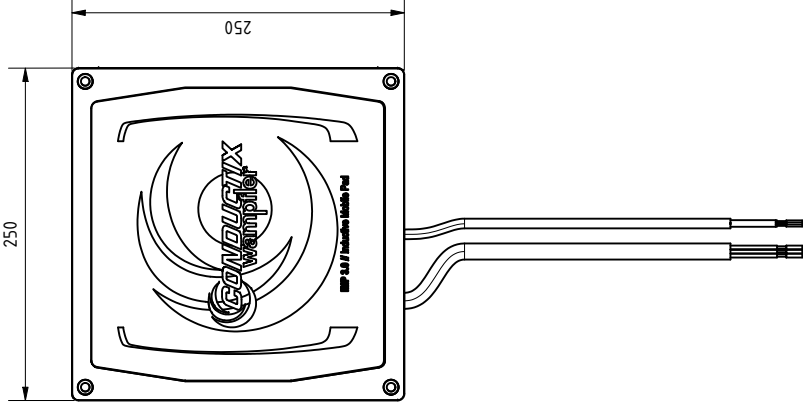
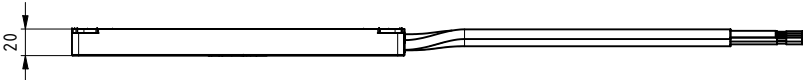
Item Number	3267891
Page	2



customer /	drawn by J.Christaller	date of drawing 17.11.2022	 status pre-series
Conductix-Wampfler Automation GmbH Handelshof 16 A 14.4.78 Potsdam Germany www.conductix.com		type of document device drawing	status of document approved
		title, additional title Inductive Mobile Pad	material number 3267993
IMP 3.0, 3kW		rev. / scale P1 1 : 4	WNR 60693000
		page 3/3	format A3

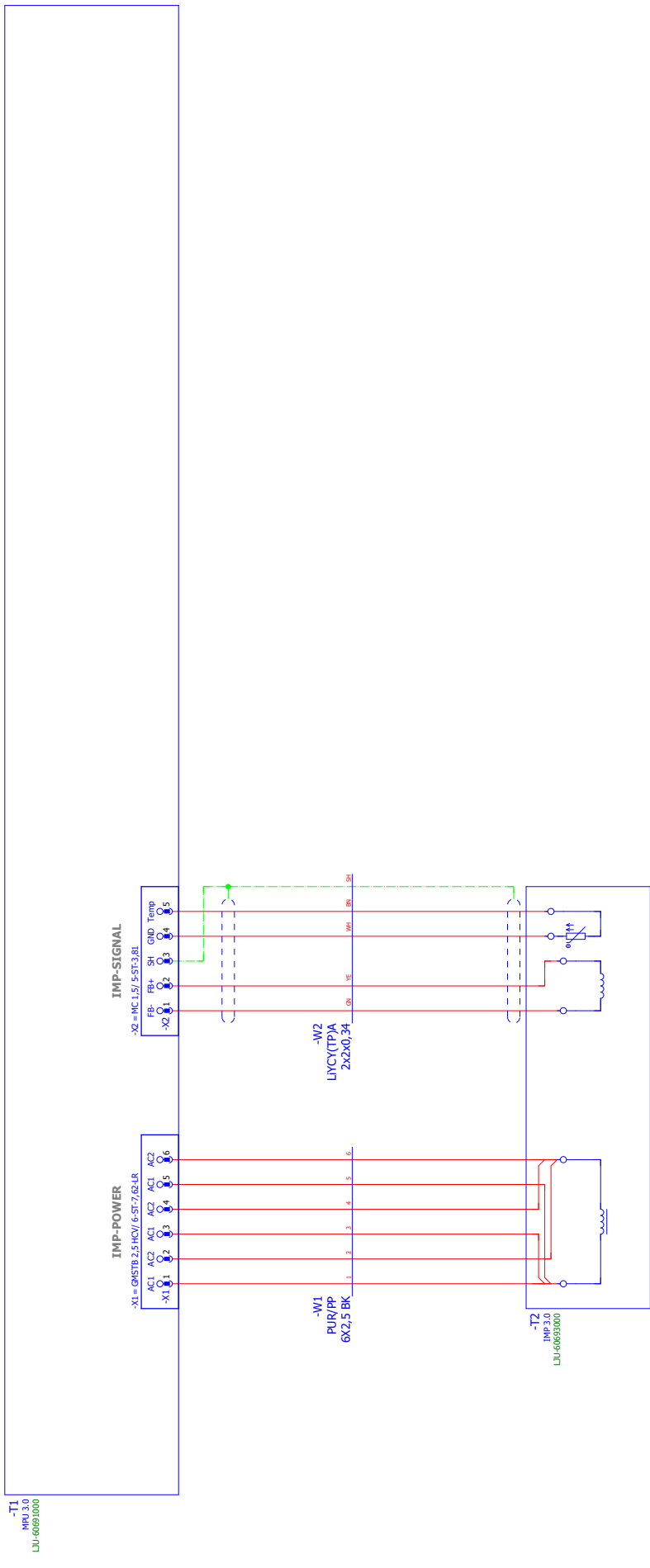

-T1
IMP 3.0
LJU-60693000

-T2
IMP 3.0
LJU-60693000